



# **SOUTH EASTERN UNIVERSITY OF SRI LANKA**

## **BIDDING DOCUMENTS FOR THE SUPPLY INSTALLATION AND COMMISSIONING OF LABORATORY FURNITURE FOR THE FACULTY OF APPLIED SCIENCE, THE SOUTH EASTERN UNIVERSITY OF SRI LANKA**

### **SEU/SS/FAS/NCB/G/2017/01**

<b>CONTENTS</b>	<b>PAGE NO</b>
<b>1. Procurement Notice</b>	<b>01</b>
<b>2. General Terms and Conditions</b>	<b>02 - 07</b>
<b>3. Bid Submission Form –Annexure I</b>	<b>09 - 10</b>
<b>4. Price Schedule –Annexure II</b>	<b>11 – 13</b>
<b>5. Technical Specifications &amp; Drawings - Annexure III</b>	<b>14 – 37</b>
<b>6. List of Goods &amp; Delivery Schedule - Annexure IV</b>	<b>38</b>
<b>7. General Terms and Conditions to be signed by the Bidder</b>	<b>39 – 44</b>
<b>8. Specimen Form for Bid Security - Annexure V</b>	<b>45 – 46</b>
<b>9. Specimen Forms for Performance Security- Annexure VI</b>	<b>47</b>
<b>10. Specimen Manufacturer’s Authorization</b>	<b>48</b>



**SOUTH EASTERN UNIVERSITY, SRI LANKA**  
**PROCUREMENT NOTICE - NCB**  
**PROCUREMENT OF LABORATORY FURNITURE**

The Chairman, Department Procurement Committee (Major) of the South Eastern University of Sri Lanka now invites sealed bids for the supply, installation and commissioning of Laboratory Equipments from eligible and qualified supplies/ reputed dealers and Manufactures

1. Bidding will be conducted through National Competitive Procedures (NCB) specified in the NPA guidelines.

S/N	Package	Detail	Bid Bond
01	Package 01	Laboratory table (12 Nos) with Accessories (Reagent shelve-06 nos, Under bench Cupboard-12 nos, Sink-06 nos, Gas valve-12 nos, Power sockets-32 nos, & Three way tap-06 nos, in each table)	LKR. 200,000.00
		Laboratory stool (150 Nos)	
		Laboratory Head table (05 Nos.) with accessories (Sink-01 nos, Gas valve-01 nos, Power sockets-04 nos, & Three way tap-01 nos in each table)	
02	Package 02	Laboratory table (64 Nos) with Accessories (Sink-32 nos, Gas valve-64 nos, Power sockets-256 nos, & Three way tap-64 nos)	LKR. 200,000.00
		Laboratory stool (130 Nos)	
		Demonstration Table (01 Nos.) with accessories (Sink-01 nos, Gas valve (01 nos), Power sockets (02 nos), & Three way tap (1 nos)	
03	Package 03	Laboratory Table with accessories (01 nos), Laboratory stool (50 nos), Wooden Glassed Cupboard (08 nos), Wooden Side Bench Solution Track (08 nos), Wooden Record Book Box (03 nos) & Wooden Demonstration Table (05 nos)	LKR. 100,000.00

2. Interested eligible bidders may obtain a complete set of Bidding Documents in English language from the Asst. Bursar/Supplies from 9.00 a.m. to 2.30 pm up to **9<sup>th</sup> March, 2017** on normal working days by producing the receipt for the payment of non-refundable fee of Rs.5000/- encashable to the shroff.
3. The Bidders can also down load the Bidding documents from the University Website i.e. <http://www.seu.ac.lk>. Those who are obtaining bidding documents from the University Website should submit the completed documents along with **Bank Draft drawn** in favor of the "**Bursar, South Eastern University of Sri Lanka, University Park, Oluvil # 32360**". And the bank draft should be attached with the Bidding documents.
4. The Bids should be accompanied with a Bid Bond/Bid Security obtained from a recognized Bank in favour of the Vice-Chancellor, South Eastern University of Sri Lanka valid for 120 days from the date of the bid opening. The sum of security should be the estimated value as specified in the bidding document.

5. Bids marked as **“Supply, Installation & Commissioning of Laboratory Furniture-SEU/SS/FAS/NCB/2017/01”** on the top left hand corner of the envelope should reach the **Chairman, Department Procurement Committee (Major), South Eastern University of Sri Lanka, University Park, Oluvil # 32360** or place in the tender box kept in the office of the Vice Chancellor, South Eastern University of Sri Lanka, on or before **2.30 p.m., 22<sup>nd</sup> March 2017**.
6. Bids will be opened in the presence of the bidders’ representatives who choose to attend in person **at 3.00 p.m. on 22<sup>nd</sup> march 2017** at The Board Room - 2, Ground Floor, Administrative Building, South Eastern University of Sri Lanka, University Park, Oluvil # 32360. Late bids will be rejected.
7. Bid shall be selected package basis
8. Pre-Bid meeting is scheduled to be held at **02.30 pm on 10<sup>th</sup> March 2017** at The Board Room - 2, Ground Floor, Administrative Building, South Eastern University of Sri Lanka, University Park, Oluvil # 32360
9. Bidder or one authorized representative of the Bidder will be permitted to be present at the opening of Bids.

**Chairman,  
Department Procurement Committee (Major),  
South Eastern University of Sri Lanka,  
University Park,  
Oluvil #32360.**

## **SOUTH EASTERN UNIVERSITY, SRI LANKA**

### **SUPPLY, INSTALLATION AND COMMISSIONING OF LABORATORY FURNITURE**

#### **01. General Terms & Condition**

- I. Bid must be sent in the prescribed form annexed (Annexure I hereto). All the bidders should sign and send the documents attached to the Annexure II containing the general terms and conditions along with the documents listed in the clause 3-II hereto. The Cost of bidding documents are paid shall not be refunded.
- II. Bids should be addressed only to the **Chairman, Procurement Committee, South Eastern University of Sri Lanka, Oluvil.**
- III. Bids should be submitted in duplicate with all the blanks in the documents duly perfected signed and dated, as follows, in two separate sealed covers, distinctly marked on the top of left hand corner of the envelope.
  - a. Original bid - **Supply of Laboratory Furniture  
SEUSL/SS/FAS/NCB/G/2017/01**
  - b. Duplicate - **Supply of Laboratory Furniture  
SEUSL/SS/FAS/NCB/G/2017/01**
- IV. Any alteration made in bids must bear the signature of the bidder and all bids containing alteration not so signed shall be treated as informal and rejected

#### **02. Closing & Opening of Bids**

Both sealed envelopes should be enclosed in one securely sealed cover and should be forwarded by Registered Post or deposited in the Official Tender Box kept at the Vice Chancellor's Office of the South Eastern University of Sri Lanka addressed only to the **Chairman, Procurement Committee, South Eastern University of Sri Lanka on or before 22<sup>nd</sup> March 2017 at 2 .30 pm.**

Bid closing date & Time: **22<sup>nd</sup> March 2017 at 2 .30 pm**

If either the original or the duplicate document thereof is not received by the date and time specified the bid shall not be accepted on any account. Bids will be opened at 3.00 pm on **22<sup>nd</sup> March 2017** at the Board Room - 2, Ground Floor, Administrative Building, South Eastern University of Sri Lanka, University Park, Oluvil # 32360.

The Bidder or one of his authorized representatives is permitted to be present at the opening of the bids.

### **03. Payment of Non-Refundable Fee**

- I. Non-refundable fee of Rs. 5,000/= should be paid either to the Shroff, South Eastern University of Sri Lanka or **Bank Draft drawn** in favor of the “**Bursar, South Eastern University of Sri Lanka, University Park, Oluvil # 32360** and the photo copy of the receipt/bank draft should be attached to the bidding documents. Those who are obtaining the bidding documents from the University website could also pay the non-refundable fee of Rs. 5,000/= to the above said Bank Account or by obtaining a Bank Draft in favour of the Bursar, South Eastern University, Sri Lanka.
- II. The bid should be made in accordance with the bidding documents consisting of the following documents
  - a. General Condition
  - b. Bid Submission Form (Annexure I)
  - c. Price Schedule (Annexure II)
  - d. Bid Security (Annexure III)
  - e. Performance Security ( Annexure IV)
  - f. Technical Specification ( Annexure V)
  - g. Copy of the Business Registration Certificate / Certificate of Incorporation / and Trading License from the local authority.
  - h. Document to support past Performance.
  - i. Any other document.
- III. Conformity with conditions and specifications all the items offered must be strictly conformed to the specifications of the Laboratory equipments and to the contents of this document. The offer must address itself specifically to the individual specifications and state whether the items offered conform or do not conform therewith. The bidder shall submit the bid in the format given at the relevant annexure, failure to do so, it will lead to rejection.

### **04. Qualification of the Bidder**

- (a) All bidders shall possess legal right to supply of goods under this procurement.
- (b) All bidders shall produce a copy of the Business Registration Certificate/ Certificate of Incorporation (if the bidder is a Company) registered under the Companies Act.
- (c) Only the bidders who are engaged in the production / business of Laboratory equipments at least for the last three years shall only be qualified to submit the bid. During that period the bidder should have similar type of supplies, completed which contract value should be exceed **Rs.3 Million**. To prove these copies of agreement or order and completion certificates should be attached with the bidding documents.

- (d) No bidder whose name is black listed by the Treasury shall be qualified to submit bid.
- (e) A bidder shall not have a conflict of interest. All bidders found to have conflict of interest shall be disqualified.
- (f) Any attempt on the part of the bidder or their agents to influence to the Officials of the University in their favour by personal canvassing with the Officers concerned or any other party shall disqualify the bidders.
- (g) Having a service center in nearby area will be considered as an added qualification.

## **05. Prices & Currencies**

The bidders shall quote the price in Sri Lankan rupees only.

## **06. The validity of Bid**

Bid shall be valid for 90 days from the date of the closing of the bids. Bid shall not be withdrawn during the period of validity of the bids.

Bid should be firm subject to no variations for fluctuations of prices.

## **07. The Value Added Tax (VAT)**

The bidder shall indicate the amount of VAT, separately in the bidding documents, in addition to the net value of the bid, along with the VAT Registration number

If the bidder not registered for VAT, the net value of the bid should be indicated in the bidding documents and a letter obtained from the Commissioner of Inland Revenue Department certifying that the bidder had not registered for VAT, should be attached with the bid documents.

If the bidder has not indicated the VAT registration number or failed to submit the letter obtained from the Department of Inland Revenue, bids shall not be considered for evaluation and shall be rejected.

## **08. Liquidated Damages**

The successful bidder shall supply, install and commission the item for which he has been issued with the order within 60 days time, from the date of the acceptance of order. In case of delayed supplies, installation and commissioning liquidated damage at the rate of Rs.5,000/- per day will be levied for maximum 04 weeks.

Bidders should be prepared to accept orders subject to the penalty clause forfeiture of performance security in the event of default in supplies or failure to supply within the stipulated period.

## **09. Bid Security**

The Bid Security furnished should be equivalent to the amount shown in the Schedule I, for each category of items. The Security should be given from a recognized Bank operates in Sri Lanka valid for **120 days from Bid opening date** in favour of the Vice-Chancellor, South Eastern University of Sri Lanka (Insurance Bond will not be accepted). Bids Submitted without the bid security shall be treated as informal and be rejected.

If the Bidder wishes to submit his bid for a part of this procurement will be accepted and should submit the Bid Security only for the bidding package.

## **10. Performance Security**

Before a formal Agreement is signed, the successful bidder shall be required to furnish a Performance Security for 10% of the contract sum from an approved Bank in the prescribed form as per Annexure, in the name of the Vice-Chancellor, South Eastern University of Sri Lanka, University Park, Oluvil #32360 for the validity period of 120 days (Contract period 90 days + additional 30 days)

## **11. Forfeiture of Performance Security**

- (a) The goods that will be supplied should be strictly be conformed to the quality and the specification as per the order given. If they are found not in par with the order shall be rejected and the Performance Security shall be forfeited to the University. The University shall not be responsible for paying any expenses or losses that may occur to the supplier in supplying the goods, non conformity with the order.
- (b) In case where a successful bidder, after having made partial supply fails to fulfill the contracts in full, all or any of the items not supplied may of the discretions of the University be purchased by means of another procurement or by negotiation or from the next higher bidder who had offered to supply already and the loss, if any caused to the University shall thereby together with the sum as may be fixed by the University towards the damages, be recovered from the defaulting bidder by forfeiting the performance security.

## **12. Evaluation of Bid**

- a) The Bids will be evaluated package basis.
- b) Only substantial responsive bids will be referred to the Technical Evaluation Committee for further evaluation and recommendation and subsequently to the Procurement Committee for a decision.
- c) The final acceptance of the procurement rests entirely to the University. The University shall not bind itself to accept the lowest or any bid. It reserves the right of accepting or rejecting any of the bids. The bidders of their part should be prepared to supply the items ordered from them what they have quoted in the bidding documents.

- d) The TEC may request samples in order to assist the selection process and check the stated quality

### **13. Notification of Acceptance**

The successful bidder will be notified by registered post, the acceptance of bid by the University. The successful bidder shall also execute an agreement, for the due fulfillment of the contract within the period to be specified in the letter of acceptance. If the bidder within ten days of being noticed declines or fails to enter into an agreement on the basis of the procurement and/or fails to submit the Performance Security referred to in paragraph 11 of these conditions, his bid shall be rejected.

The official intends will be placed with the successful bidder after the submission of Performance Security referred to in paragraph 11 of the conditions.

### **14. Delivering, Installation and Commissioning,**

- a) The bidder will be responsible for proper packing, transport and deliver the furniture to the South Eastern University of Sri Lanka.
- b) The furniture should be assembled, installed as directed by the University and commissioned soon after the items are delivered.

### **15. Payment Terms**

- a) Payment will be made by cheque drawn in favour of the **Business name of the bidder with "Account Payee only" crossing.**
- b) The payment will be made as follows,
- |     |                                    |   |                  |
|-----|------------------------------------|---|------------------|
| I.  | Delivery and installation of Goods | - | 80% of the value |
| II. | Commissioning of Goods             | - | 20% of the value |

### **16. Assigning & Subletting of Contract.**

The selected bidder shall not assign or sublet the supply or any part of thereof.

### **17. Termination of Contract.**

The Chairman University Procurement Committee of the South Eastern University of Sri Lanka may without prejudice to any other remedy for breach of contract written notice of default send to the supplier terminate the contract in whole or part thereof.

Or

If the Contractor fails to perform any other obligation under the contract and if the Contractor, in either of the above circumstances does not response within a period of



10 days after receipt of the notice of default from the Chairman specifying the nature of the defaulters.

If any further information is needed, that could be obtained from the Assistant Bursar/Stores and Supplies SEUSL on any working day between 9.00 a.m and 3.00 p.m on Telephone Numbers: 067 2255178

## **18. Clarification of Bidding Documents**

a). A prospective Bidder requiring any clarification of the Bidding Documents including the restrictiveness of specifications shall contact the Purchaser in writing at the **Senior Assistant Bursar, South Eastern University of Sri Lanka, University Park, Oluvil # 32360** marked as **“Supply, Installation & Commissioning of Laboratory Furniture- SEU/SS/FAS/NCB/2017/01”**. The letter should reach no later than ten (10) days prior to the deadline for submission of bids.

b). Pre-Bid meeting is scheduled to be held at 02.30 pm on **10<sup>th</sup> March 2017** at The Board Room - 2, Ground Floor, Administrative Building, South Eastern University of Sri Lanka, University Park, Oluvil # 32360

**Chairman,  
Department Procurement Committee (Major),  
South Eastern University of Sri Lanka,  
University Park,  
Oluvil #32360.**

**SOUTH EASTERN UNIVERSITY, SRI LANKA****SUPPLY, INSTALLATION AND COMMISSIONING OF LABORATORY FURNITURE****BID SUBMISSION FORM**

To:  
 Chairman  
 Procurement Committee  
 South Eastern University, Sri Lanka  
 Oluvil.

We, the undersigned, declare that:

1. We have examined and have no reservations to the Bidding Documents, including Addenda No.:
2. We offer to supply in conformity with the Bidding Documents and in accordance with the Delivery Schedules specified in the Schedule of Requirements the following Goods and Related Services
3. The total price of our Bid without VAT, including any discounts offered is:

Package No 01		Total Cost in Figure without VAT		Discounted Total Cost in Figure with VAT	
		Rs.	Cts	Rs.	Cts
01	Package 01				
Final offer amount in Words					

Package No 02		Total Cost in Figure without VAT		Discounted Total Cost in Figure with VAT	
		Rs.	Cts	Rs.	Cts
02	Package 02				
Final offer amount in Words					

.....  
 Seal & Signature of the Bidder

Package No 03		Total Cost in Figure without VAT		Discounted Total Cost in Figure with VAT	
		Rs.	Cts	Rs.	Cts
03	Package 03				
<b>Final offer amount in Words</b>					

4. Our bid shall be valid for the period of time specified in Clause 06, from the date fixed for the bid submission deadline in accordance with Clause 02, and it shall remain binding upon us and may be accepted at any time before the expiration of that period;
5. If our bid is accepted, we commit to obtain a performance security in accordance with Clause 10 and 11 for the due performance of the Contract;
6. Our firm, its affiliates or subsidiaries—including any subcontractors or suppliers for any part of the contract—has not been declared blacklisted by the National Procurement Agency;
7. We understand that this bid, together with your written acceptance thereof included in your notification of award, shall constitute a binding contract between us, until a formal contract is prepared and executed.
8. We understand that you are not bound to accept the lowest and that you reserve the right to reject any or all bids or to accept any part of procurement in the best interest of the University without assigning any reasons thereof.

**Name of Bidder**

**Seal**

**Signature of Bidder**

**Name and Title of the Signatory  
Telephone and Fax No**

**Name of Witness**

**Signature of Witness**

**NIC Nob**

**Address**

**Date**

**PRICE SCHEDULE**

ANNEXURE - II

SEUSL/SS/FAS/NCB/G/2017/01

**Package 01: Chemistry Lab**

S/N	Description	(1)	(2)	(3)	(4)	(5)	(6)	(7)	(8)	(9)
		Qty	Unit Price	Discounts if any	Discounted Price	VAT	Price with VAT (4+5)	Sub Total (1x6)	Brand & Warranty	Remarks
<b>01</b>	<b>Laboratory table with Accessories</b>									
1.1	Table	12								
1.2	Reagent shelf	72								
1.3	Cupboard (Under bench)	144								
1.4	Sink	72								
1.5	Gas valve	144								
1.6	Power sockets	384								
1.7	Three way tap	72								
<b>02</b>	<b>Laboratory Stool</b>	150								
<b>03</b>	<b>Head Table with Accessories</b>									
3.1	Table	05								
3.2	Sink	05								
3.3	Gas valve	05								
3.4	Power sockets	20								
3.5	Three way tap	05								
<b>Other Charges (Installation/Transportation) .....</b>										
<b>Total bid amount for Package 01</b>										

Date: .....

Company Name : .....

Signature : .....

Name of the authorized person : .....

Contact Number : .....

Company Seal &amp; Address :

**PRICE SCHEDULE**

SEUSL/SS/FAS/NCB/G/2017/01

**Package 02: Biology Lab**

S/N	Description	(1)	(2)	(3)	(4)	(5)	(6)	(7)	(8)	(9)
		Qty	Unit Price	Discounts if any	Discounted Price	VAT	Price with VAT (4+5)	Sub Total (1x6)	Brand & Warranty	Remarks
<b>04</b>	<b>Laboratory Table with Accessories</b>									
4.1	Table	64								
4.2	Sink	32								
4.3	Gas valve	64								
4.4	Power sockets -5A	128								
	Power sockets -13A	128								
4.5	Three way tap	64								
<b>05</b>	<b>Laboratory Stool</b>	130								
<b>06</b>	<b>Demonstration Table with Accessories</b>									
6.1	Table	01								
6.2	Sink	01								
6.3	Gas valve	01								
6.4	Power sockets -5A	01								
	Power sockets -13A	01								
6.5	Three way tap	01								
<b>Other Charges (Installation/Transportation) .....</b>										
<b>Total bid amount for Package 02</b>										

Date: .....

Company Name : .....

Signature : .....

Name of the authorized person : .....

Contact Number : .....

Company Seal &amp; Address :

**PRICE SCHEDULE**

SEUSL/SS/FAS/NCB/G/2017/01

**Package 03: Earth Science Lab**

S/ N	Description	(1)	(2)	(3)	(4)	(5)	(6)	(7)	(8)	(9)
		Qty	Unit Price	Discounts if any	Discounted Price	VAT	Price with VAT (4+5)	Sub Total (1x6)	Brand & Warranty	Remarks
07	(F1) Wooden Laboratory Table with accessories	01								
08	(F2) Laboratory stool - I	30								
09	(F3) Laboratory stool - II	20								
10	(F4) Wooden Glassed Cupboard	08								
11	(F5) Wooden Side Bench Solution Track	08								
12	(F6) Wooden Record Book Box, Timber type	03								
13	(F8) Wooden Demonstration Table	05								
<b>Other Charges (Installation/Transportation) .....</b>										
<b>Total bid amount for Package 03</b>										

Date: .....

Company Name : .....

Signature : .....

Name of the authorized person : .....

Contact Number : .....

Company Seal &amp; Address :

## Technical Specifications

ANNEXURE - III

### Package 1: Chemistry Lab

Item No.	Item Name	Listed Specification		Conformity to specification "YES"/ "NO"		BIDDERS RESPONSE
				Yes	No	
01	<b>Laboratory table with Accessories</b>					
01.1	<b>Table</b>	Dimension	5400 x 1400 x 900 mm			
		Material	Material shall be wooden resistance to chemical and should not deform or de-shaped at elevated environmental conditions. all the surfaces should not absorb any toxic substances All wooden material should be seasoned and pressure treated			
		Work top	Phenolic resin worktop constructed conforming to chemical and stain resistant characteristics.			
		Finishing	The finished material shall be extremely hard and resistance to scratches and impact. (resistance to chemical and should not deform or de-shaped at elevated environmental conditions. all the surfaces should not absorb any toxic substances)			
		Thickness	Minimum 1 1/2" (one and half inch)			
		Edges and corners	Edges and corners Exposed work surface edge and corners shall be finished with a beveled edge Back splashes to be installed for all the wall edges where appropriate.			
	<b>Accessories (Including fittings, fixtures and all necessary accessories to fix accessories)</b>					
1.2	<b>Reagent</b>	Dimension	750mm x 240mm x 720 mm			

	<b>shelve</b>	Material	Material shall be wooden or any other standard material resistance to chemical and should not deform or de-shaped at elevated environmental conditions. All wooden material should be seasoned and pressure treated			
1.3	<b>Cupboard</b> (Under bench)	Dimension	440x540x750 mm			
		Material	Material shall be wooden or any other standard material resistance to chemical and should not deform or de-shaped at elevated environmental conditions. All wooden material should be seasoned and pressure treated			
1.4	<b>Sink</b>		Anti-siphon sink with bottle trap & waste			
		Size	450 x 300 x 200 mm			
1.5	<b>Gas valve</b>		Material brass, double way bench mounted gas valve			
1.6	<b>Power sockets</b>		13A			
			Universal type			
1.7	<b>Three way tap</b>		Material brass, Bench Mount, Swivel Necks, Removable Nozzle			
02	<b>Stool</b>	Dimension	300x300x600 mm			
		Material	Material shall be wooden or any other standard material resistance to chemical and should not deform or de-shaped at elevated environmental conditions. All wooden material should be seasoned and pressure treated			



03	<b>Laboratory Head table with Accessories</b> (Including fittings, fixtures and all necessary accessories to fix accessories)					
3.1	<b>Head Table</b>	Dimension	1600x1000x900 mm			
		Material	Material shall be wooden resistance to chemical and should not deform or de-shaped at elevated environmental conditions. all the surfaces should not absorb any toxic substances All wooden material should be seasoned and pressure treated			
		Work top	Phenolic resin worktop constructed conforming to chemical and stain resistant characteristics.			
		Finishing	The finished material shall be extremely hard and resistance to scratches and impact (resistance to chemical and should not deform or de-shaped at elevated environmental conditions. all the surfaces should not absorb any toxic substances)			
		Thickness	Minimum 1 1/2" (one and half inch)			
		Edges and corners	Edges and corners Exposed work surface edge and corners shall be finished with a beveled edge Back splashes to be installed for all the wall edges where appropriate.			
<b>Accessories (Including fittings, fixtures and all necessary accessories to fix accessories)</b>						
3.2	<b>Sink</b>		Anti-siphon sink with bottle trap & waste			
3.3	<b>Gas valve</b>		Double way bench mounted gas valve			
3.4	<b>Power sockets</b>		13A			
			Universal type			
3.5	<b>Three way tap</b>		Material brass, Bench Mount, Swivel Necks, Removable Nozzle			

**Package 2: Biology Lab**

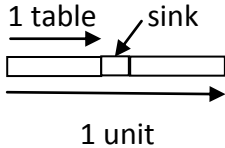
Item No.	Item Name	Listed Specification		Conformity to specification "YES"/ "NO"		BIDDERS RESPONSE
				Yes	No	
04	<b>Laboratory table with necessary accessories</b>					
04.1	<b>Table</b>	Dimension	01 Unit = 3048 x 600 x 900 mm 01 Table = 1325 x 600 x 900 mm  			
		Material	Material shall be wooden (Teak) with non-porous coating or any other standard material resistance to chemical and should not deform or de-shaped at elevated environmental conditions. All the surfaces should not absorb any toxic substances. All wooden material should be seasoned and pressure treated			
		Work top	Phenolic resin worktop constructed conforming to chemical and stain resistant characteristics.			
		Finishing	The finished material shall be extremely hard and resistance to scratches and impact (non-porous coating or any other standard material resistance to chemical and should not deform or de-shaped at elevated environmental conditions)			
		Thickness	Minimum 01" (one inch)			
		Edges and corners	Edges and corners Exposed work surface edge and corners shall be finished with a beveled edge Back splashes to be installed for all the wall edges where appropriate.			
	<b>Accessories (Including fittings, fixtures and all necessary accessories to fix accessories)</b>					

4.2	<b>Sink</b>		Polypropylene sink (Drop-in)- (industry standard) with bottle trap & waste			
		Size	548 x 398 x 235 mm			
4.3	<b>Gas valve</b>		Material brass, Two way bench mounted gas valve			
4.4	<b>Power sockets</b>		05A -Universal type			
			13A -Universal type			
4.5	<b>Three way tap</b>		Material brass, Bench Mount, Swivel Necks, Removable Nozzle			
05	<b>Stool</b>	Dimension	396.24mm x 396.24 mm x 670.56 mm			
		Material	Material shall be wooden (teak) or any other standard material resistance to chemical and should not deform or de-shaped at elevated environmental conditions. All wooden material should be seasoned and pressure treated			
06	<b>Laboratory Head table with Accessories</b> (Including fittings, fixtures and all necessary accessories to fix accessories)					
6.1	<b>Head Table</b>	Dimension	As per the given drawing			
		Material	Material shall be wooden (teak) resistance to chemical and should not deform or de-shaped at elevated environmental conditions. all the surfaces should not absorb any toxic substances All wooden material should be seasoned and pressure treated			
		Work top	Phenolic resin worktop constructed conforming to chemical and stain resistant characteristics.			

		Finishing	The finished material shall be extremely hard and resistance to scratches and impact (resistance to chemical and should not deform or de-shaped at elevated environmental conditions. all the surfaces should not absorb any toxic substances)			
		Thickness	Minimum 1" (one inch)			
		Edges and corners	Edges and corners Exposed work surface edge and corners shall be finished with a beveled edge			
			Back splashes to be installed for all the wall edges where appropriate.			
	<b>Accessories</b> (Including fittings, fixtures and all necessary accessories to fix accessories)					
6.2	<b>Sink</b>		Polypropylene sinks (drop – in) with bottle trap & waste			
		Size	548 x 398 x 235 mm			
6.3	<b>Gas valve</b>		Two way bench mounted gas valve, Material brass			
6.4	<b>Power sockets</b>		05A - Universal type			
			13A - Universal type			
6.5	<b>Three way tap</b>		Material brass, Bench Mount, Swivel Necks, Removable Nozzle			

**Package 3: Earth Science Lab**

Item No.	Item Name	Listed Specification		Conformity to specification "YES"/ "NO"		BIDDERS RESPONSE
				Yes	No	
07	(F1) Wooden Laboratory Table with fittings, fixtures and all necessary accessories as described in the drawings)	Timber Type	Teak			
		Top Surface	Top surface material polypropylene (PP)			
		Size	3600 mm X 1500 mm X 925 mm, Thickness is 25 mm			
08	(F2) Laboratory stool – I	Timber Type	Teak			
		Size	560 mm x 380 mm X 535 mm			
09	(F3) Laboratory stool – II	Timber Type	Teak			
		Size	300 mm X 300 mm X 652 mm			
10	(F4) Wooden Glassed Cupboard	Timber Type	Teak			
		Size	1000 mm X 500 mm X 1925 mm, Thickness is 25 mm			
11	(F5) Wooden Side Bench Solution Track	Timber Type	Teak			
		Size	1800 mm X 300 mm X 2175 mm, Thickness is 25 mm			
12	(F6) Wooden Record Book Box	Timber Type	Teak			
		Size	325 mm X 450 mm X 525 mm, Thickness is 25 mm			
13	(F8) Wooden Demonstration Table	Timber Type	Teak			
		Size	1350 mm X 900 mm X 750 mm, Thickness is 25 mm			
<b>All wooden material should be seasoned and pressure treated</b>						

## Technical Specifications (Drawings)- Package 1: Chemistry Lab

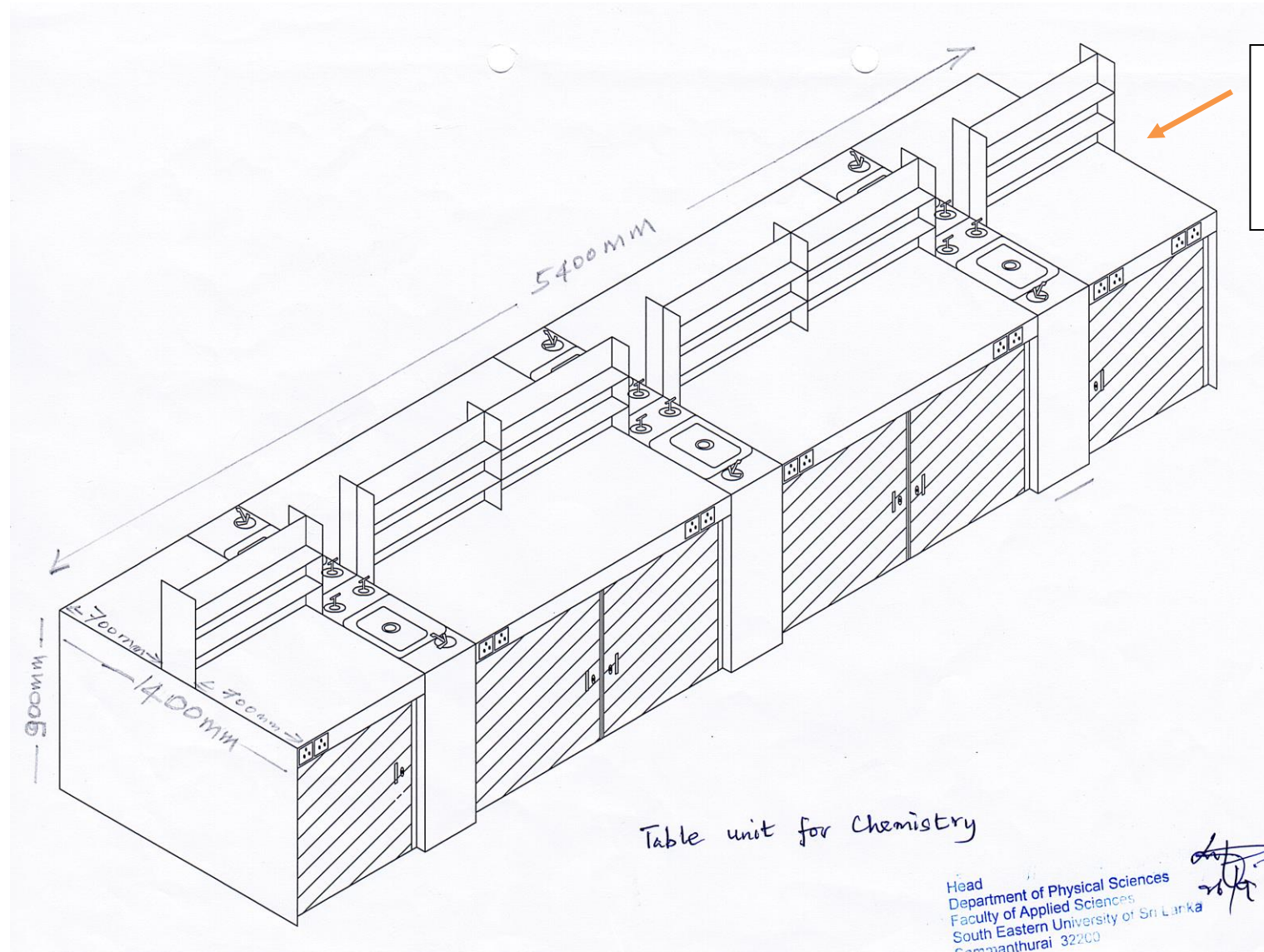

This could be a single unit or assembled 4 pices as shown in the picture

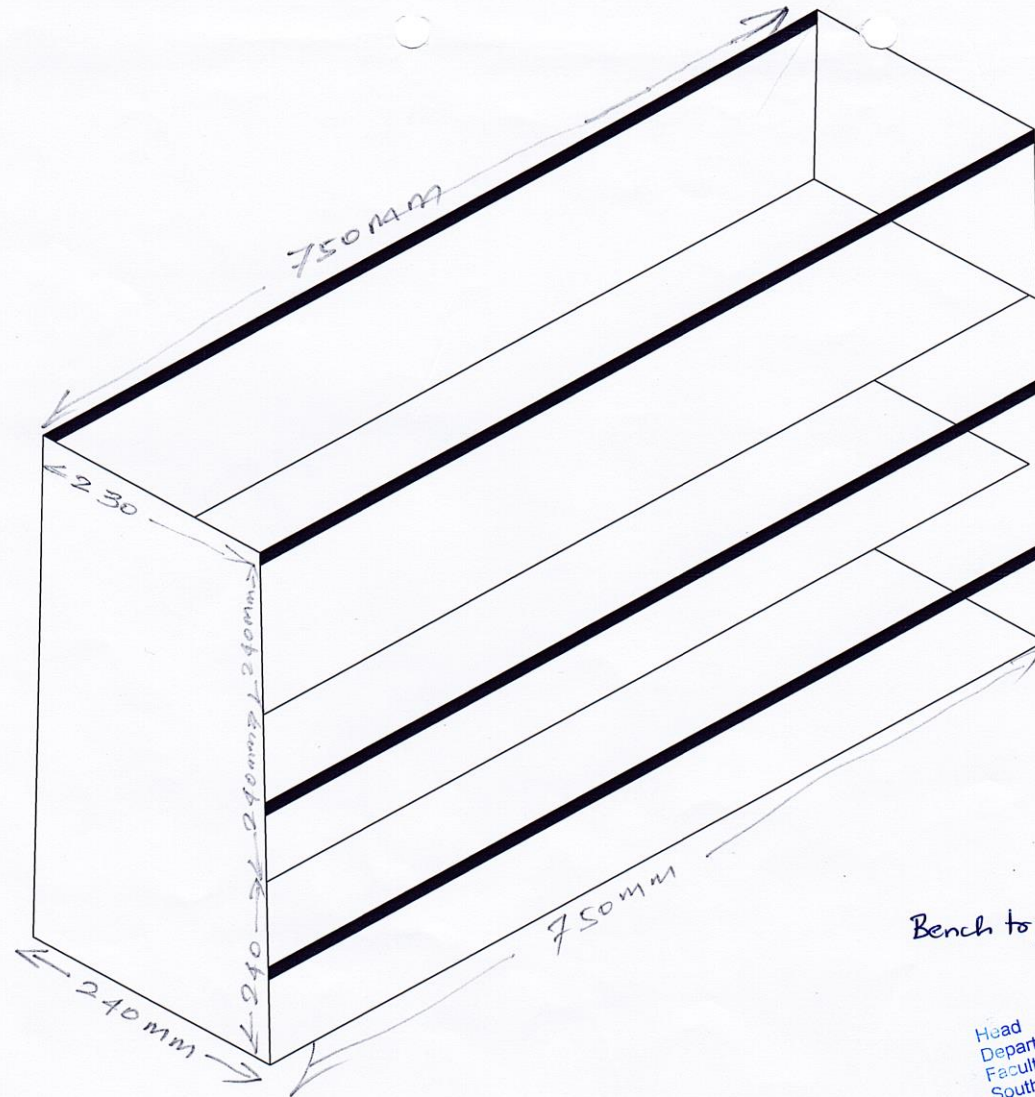

Bench top chemical set shelf.

Head  
Department of Physical Sciences  
Faculty of Applied Sciences  
South Eastern University of Sri Lanka  
Sammanthurai 32200

26/2

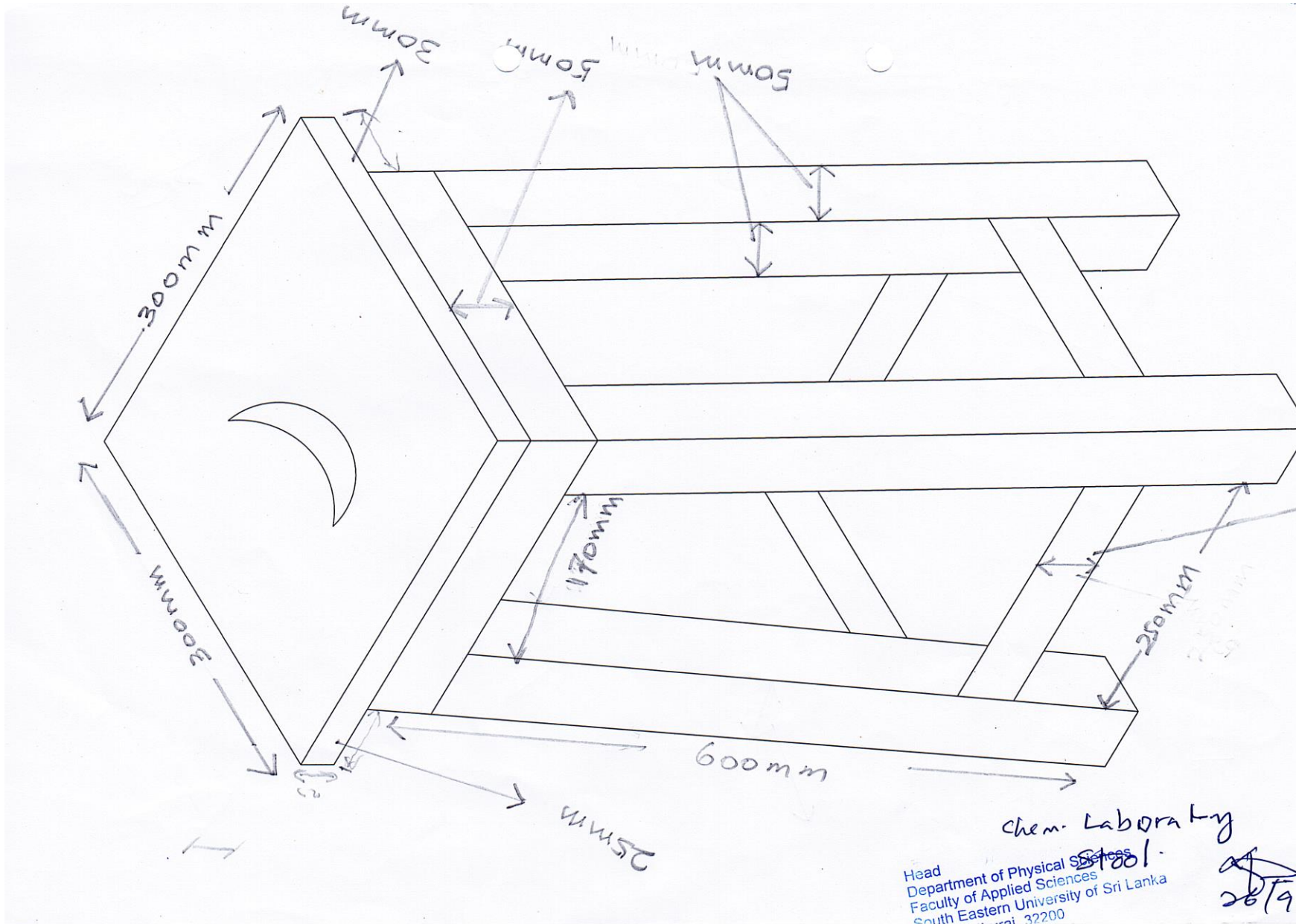

Head  
Department of Physical Sciences  
Faculty of Applied Sciences  
University of Sri Lanka  
South Eastern 32200

6/9/2017



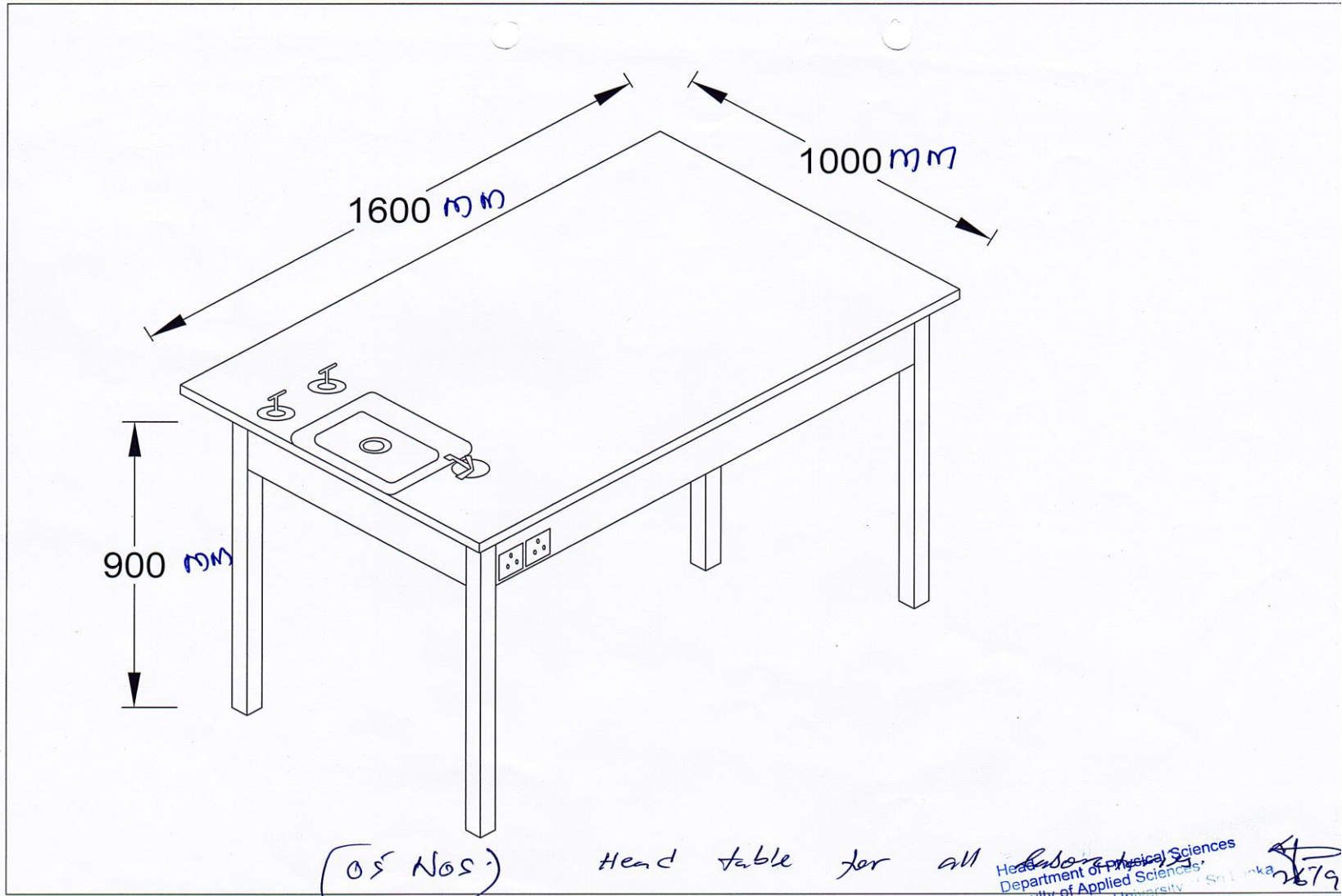

## Technical Specifications (Drawings)- Package 02: Biology Lab

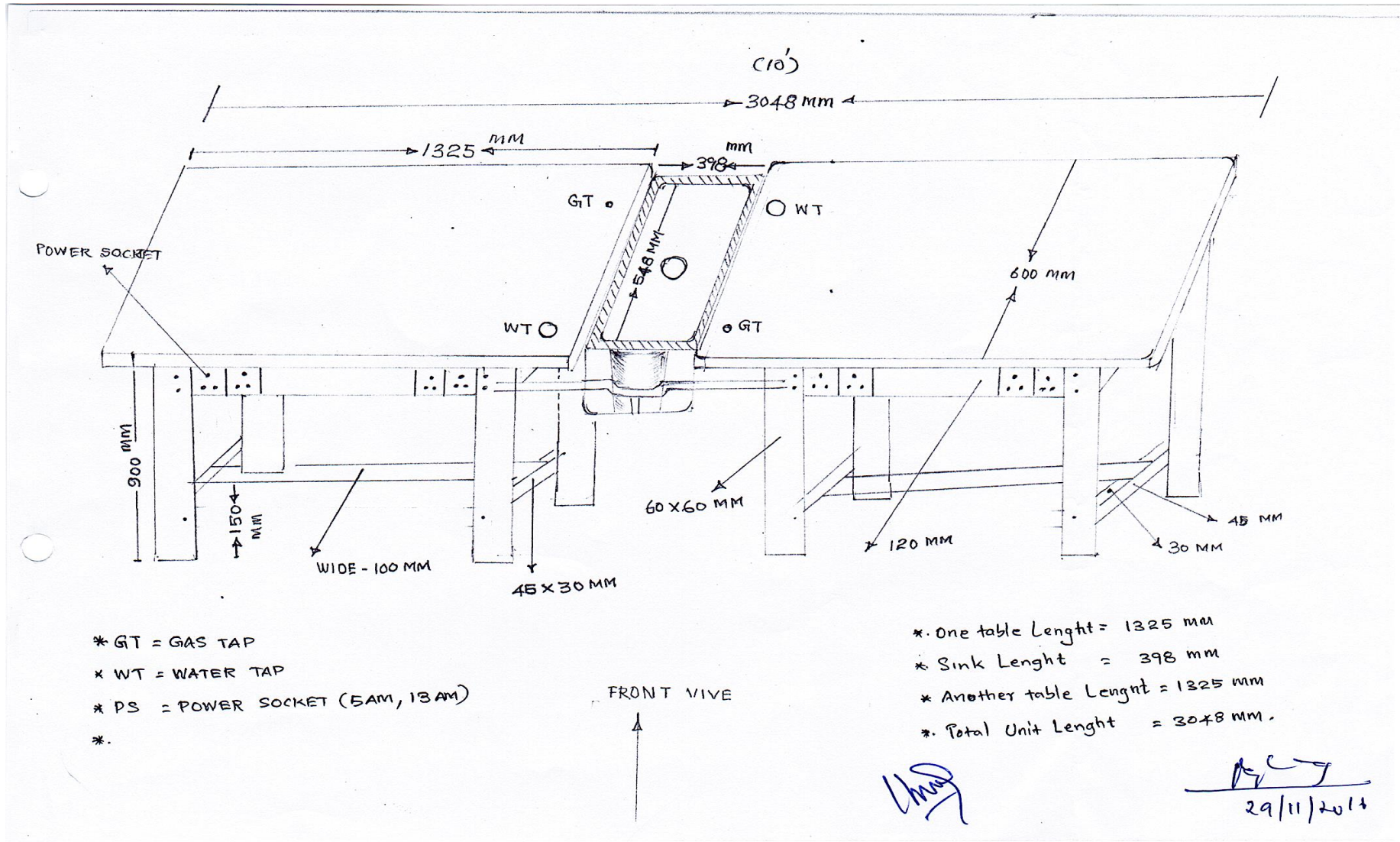

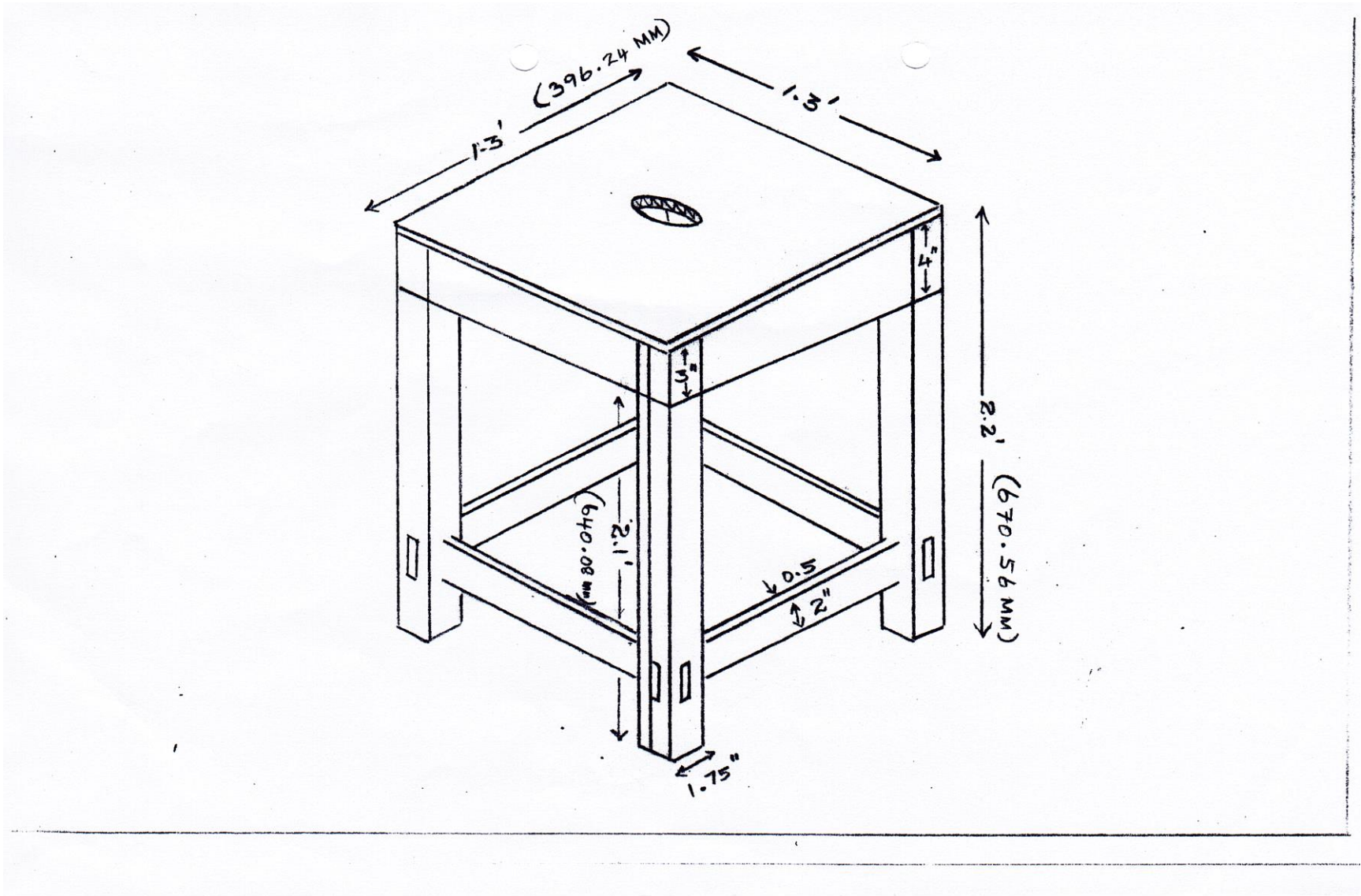

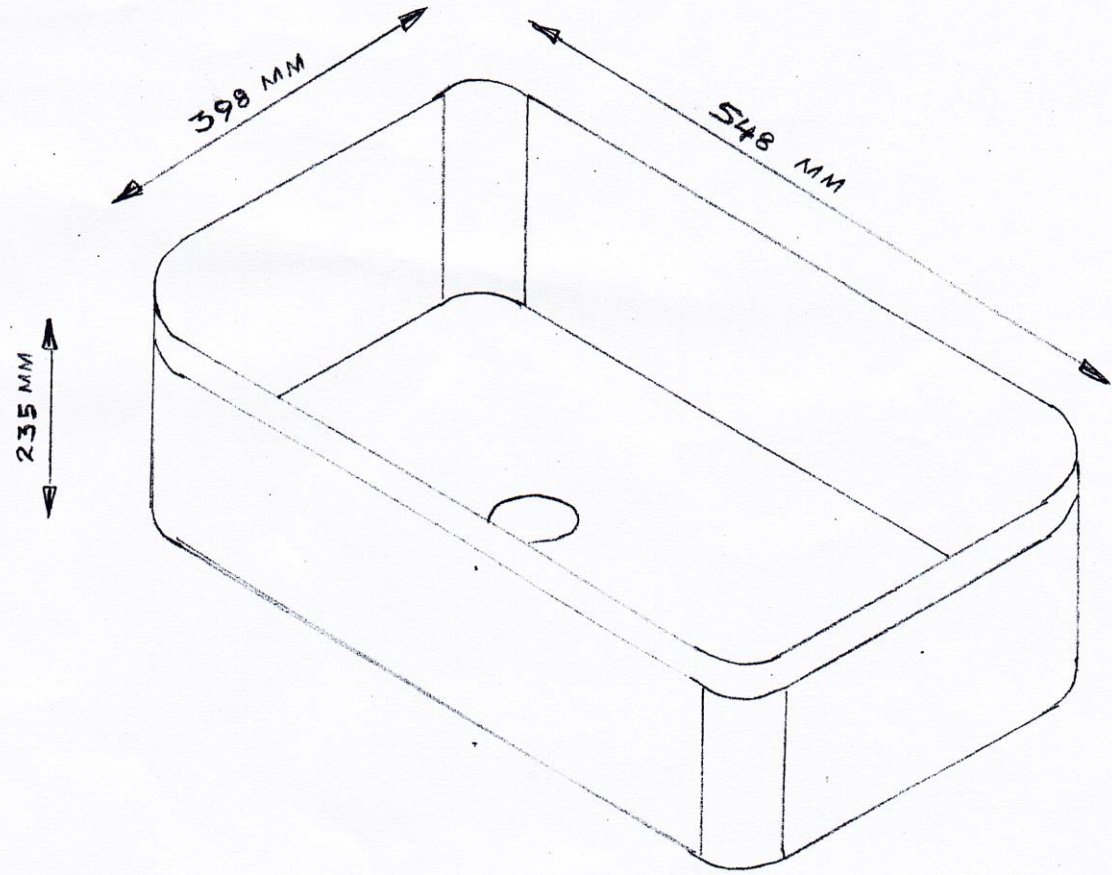

STRUCTURE OF LABORATORY DEMONSTRATION BENCH. FOR NEW BIOLOGY LAB FAS

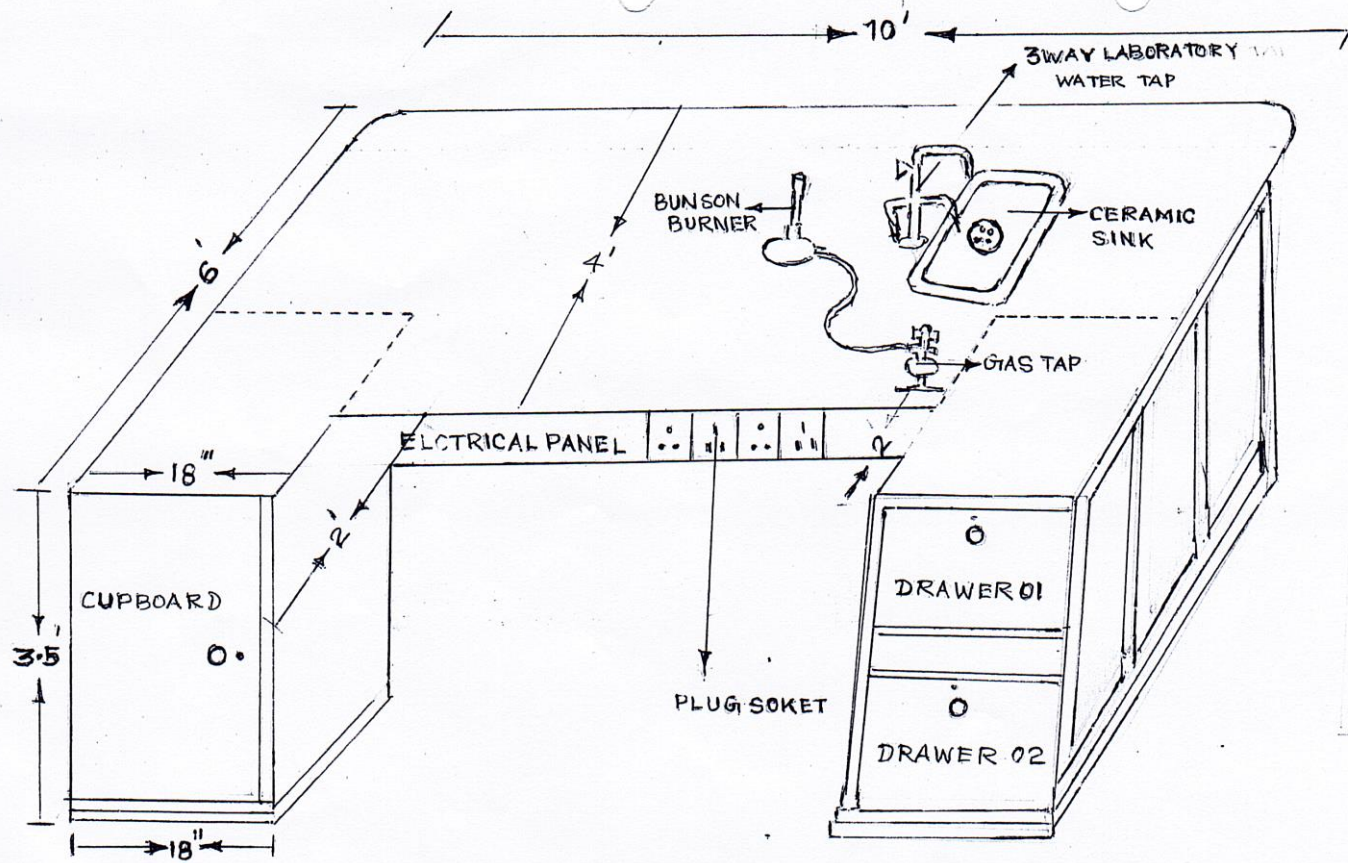

TITLE (WOOD)

LENGTH - 10'  
WIDE - 6,  
HEIGHT - 3.5'

TOP VIEW

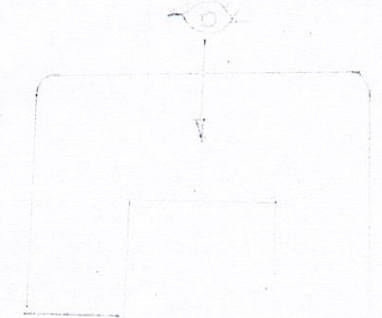

DESIGNIG BY  
*Rasool*  
Dept of Biology

# Technical Specifications (Drawings)- Package 03: Earth Science Lab

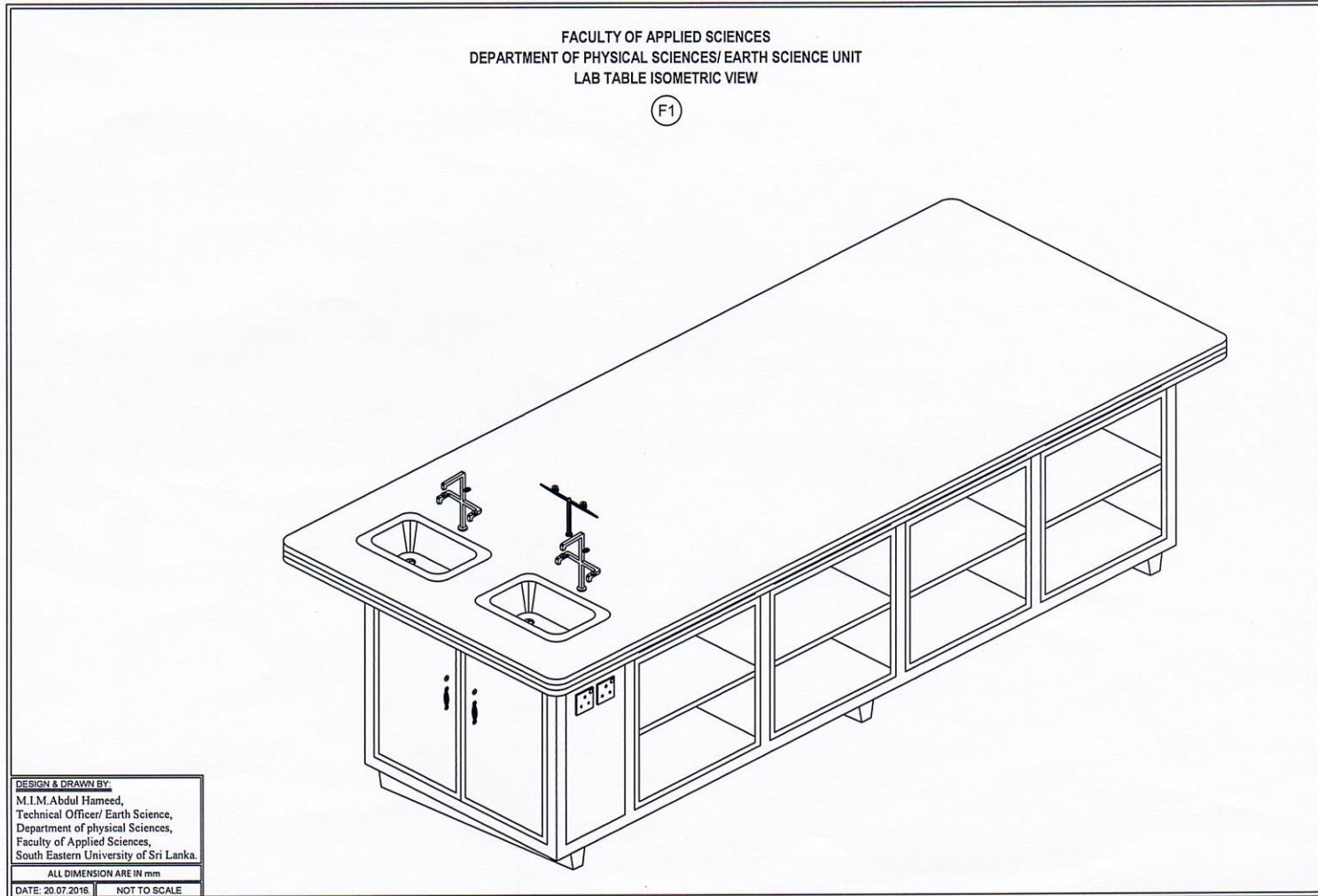

FACULTY OF APPLIED SCIENCES  
 DEPARTMENT OF PHYSICAL SCIENCES/ EARTH SCIENCE UNIT  
 LAB TABLE VIEWS

(F1)

TOP VIEW

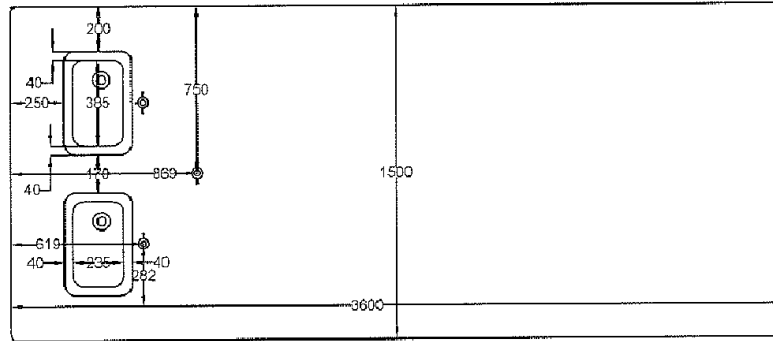

SIDE VIEW

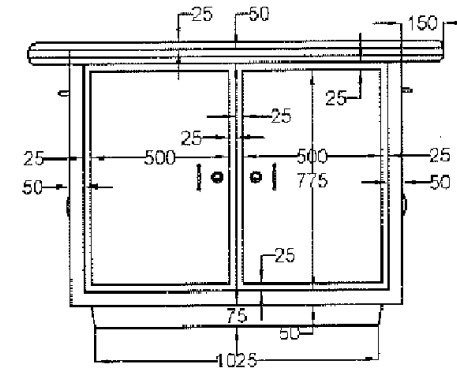

FRONT VIEW

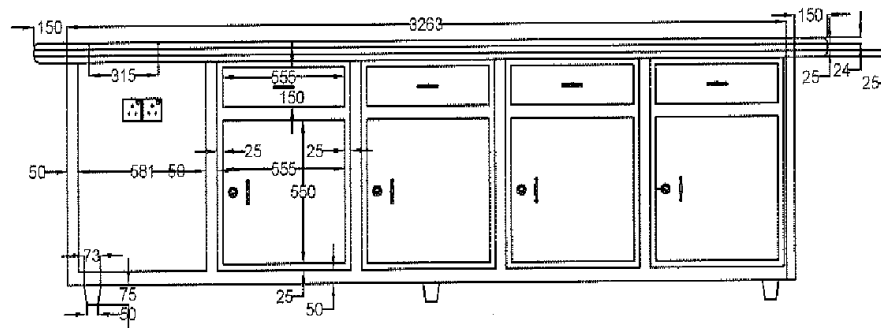

DESIGN & DRAWN BY:  
 M.I.M. Abdul Hameed,  
 Technical Officer/ Earth Science,  
 Department of physical Sciences,  
 Faculty of Applied Sciences,  
 South Eastern University of Sri Lanka.

ALL DIMENSION ARE IN mm

DATE: 20.07.2016 NOT TO SCALE

FACULTY OF APPLIED SCIENCES  
DEPARTMENT OF PHYSICAL SCIENCES/ EARTH SCIENCE UNIT  
LAB STOOL VIEW - I

(F2)

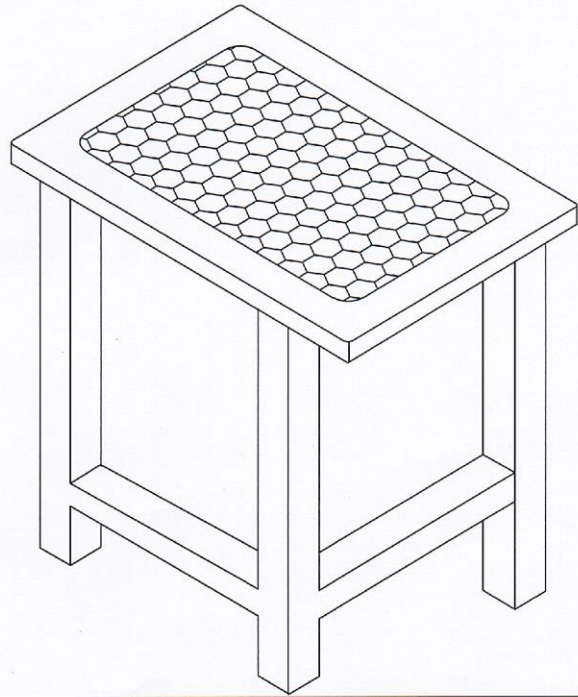

TOP VIEW

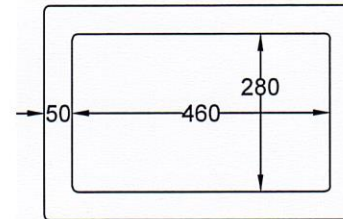

FRONT VIEW

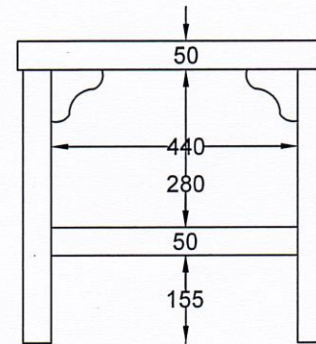

SIDE VIEW

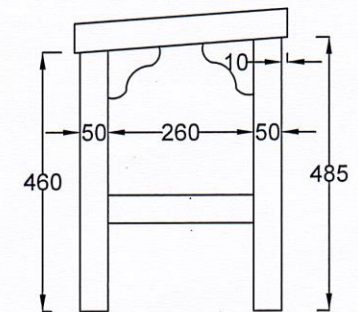

DESIGN & DRAWN BY:  
M.I.M. Abdul Hameed,  
Technical Officer/ Earth Science,  
Department of physical Sciences,  
Faculty of Applied Sciences,  
South Eastern University of Sri Lanka.  
ALL DIMENSION ARE IN mm  
DATE: 20.07.2016. NOT TO SCALE



FACULTY OF APPLIED SCIENCES  
 DEPARTMENT OF PHYSICAL SCIENCES/ EARTH SCIENCE UNIT  
 LAB STOOL VIEW - II

(F3)

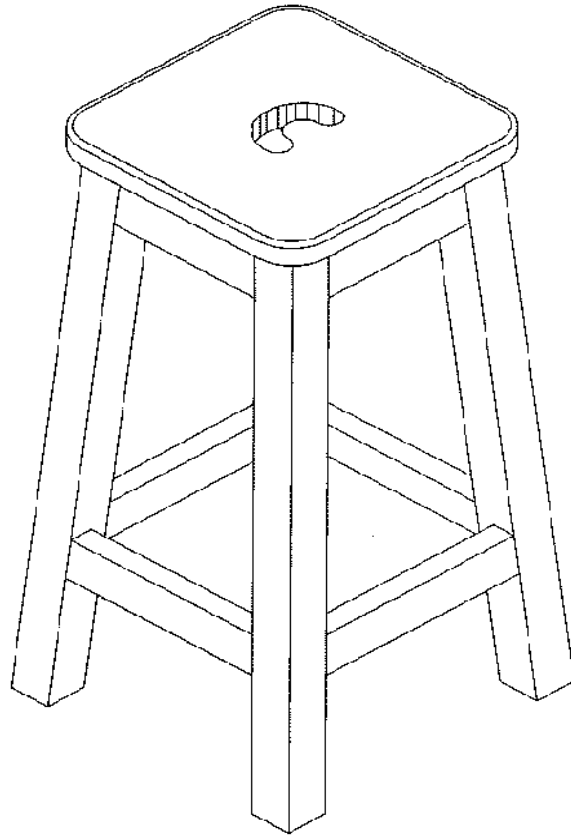

TOP VIEW

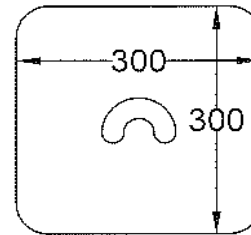

TOP VIEW

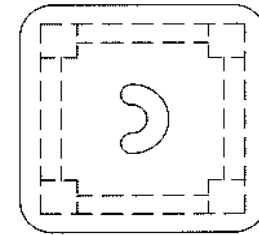

FRONT VIEW

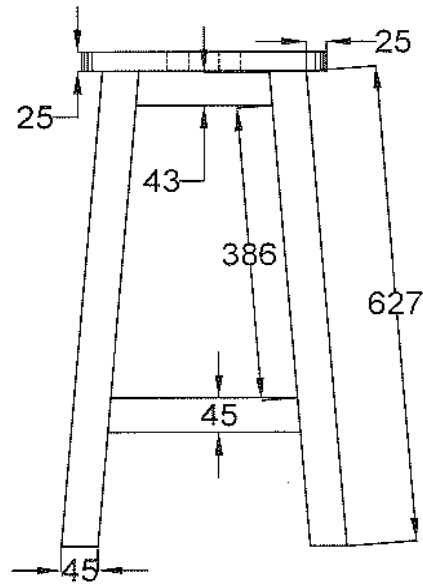

SIDE VIEW

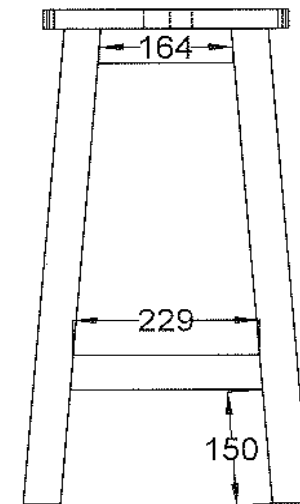

DESIGN & DRAWN BY  
 M.T.M Abdul Hameed,  
 Technical Officer/ Earth Science,  
 Department of physical Sciences,  
 Faculty of Applied Sciences,  
 South Eastern University of Sri Lanka.

ALL DIMENSIONS ARE IN mm

DATE: 20.07.2016. NOT TO SCALE

FACULTY OF APPLIED SCIENCES  
 DEPARTMENT OF PHYSICAL SCIENCES/EARTH SCIENCE UNIT  
 WOODEN GLASSED CUPBOARD VIEW

(F4)

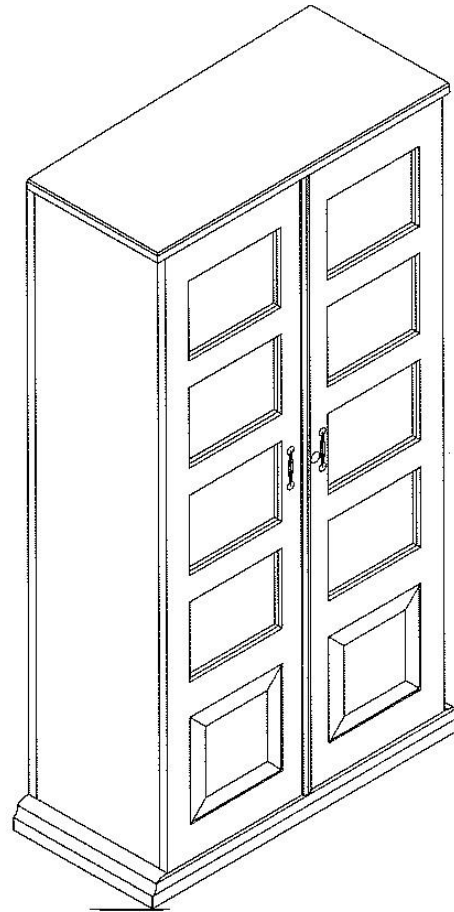

TOP VIEW

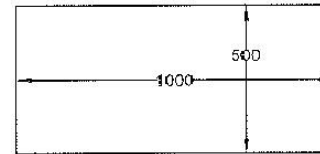

FRONT VIEW

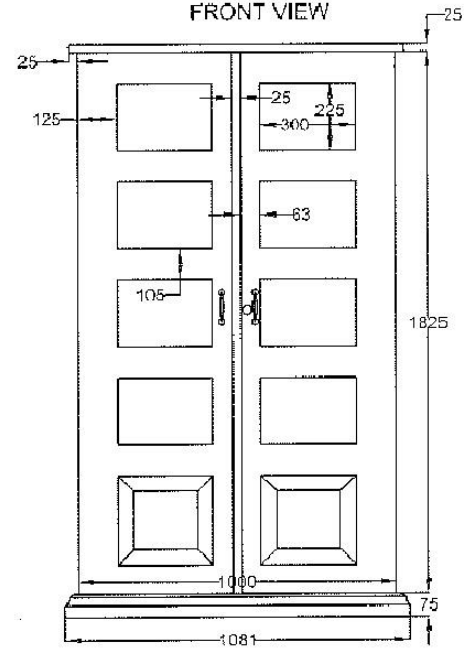

SIDE VIEW

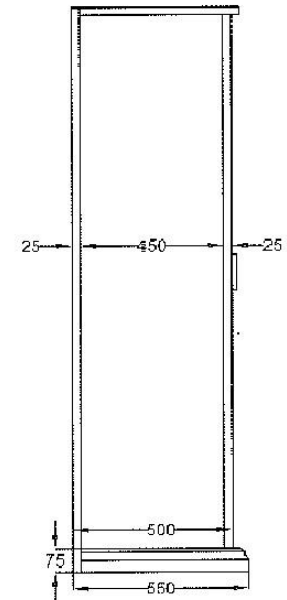

DESIGN & DRAWN BY:  
 M LM Abdul Hameed,  
 Technical Officer/ Earth Science,  
 Department of physical Sciences,  
 Faculty of Applied Sciences,  
 South Eastern University of Sri Lanka.  
 ALL DIMENSION ARE IN mm  
 DATE: 20.07.2016 NOT TO SCALE

Handwritten signature or initials in the bottom right corner of the drawing area.

FACULTY OF APPLIED SCIENCES  
DEPARTMENT OF PHYSICAL SCIENCES/ EARTH SCIENCE UNIT  
SIDE BENCH SOLUTION TRACK VIEW

(F5)

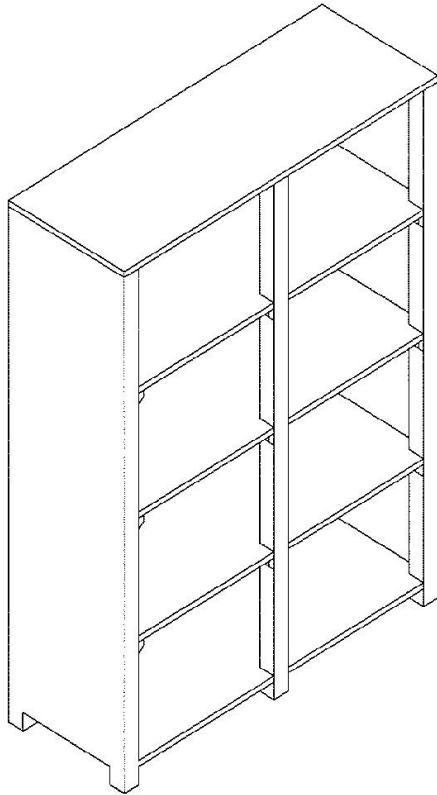

TOP VIEW

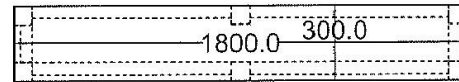

FRONT VIEW

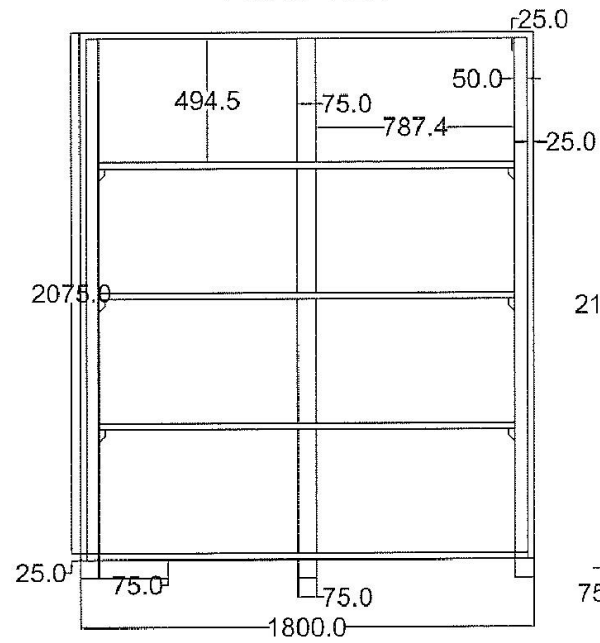

SIDE VIEW

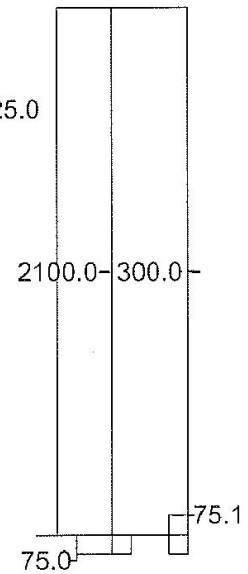

DESIGN & DRAWN BY:  
M.I.M. Abdul Hameed,  
Technical Officer/ Earth Science,  
Department of physical Sciences,  
Faculty of Applied Sciences,  
South Eastern University of Sri Lanka  
ALL DIMENSION ARE IN mm  
DATE: 20.07.2016 NOT TO SCALE

FACULTY OF APPLIED SCIENCES  
 DEPARTMENT OF PHYSICAL SCIENCES/ EARTH SCIENCE UNIT  
 RECORD BOOK BOX VIEW

(F6)

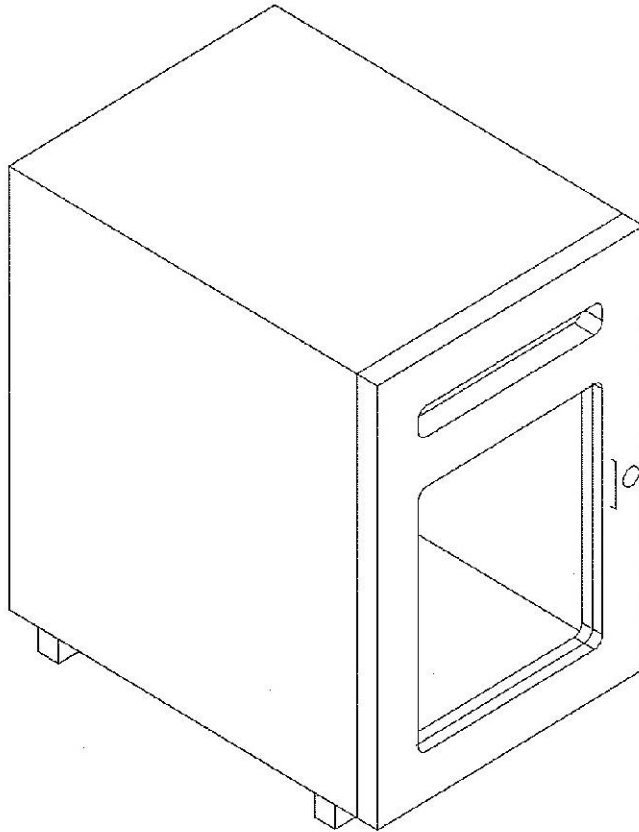

TOP VIEW

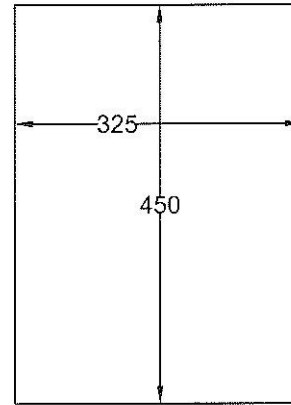

SIDE VIEW

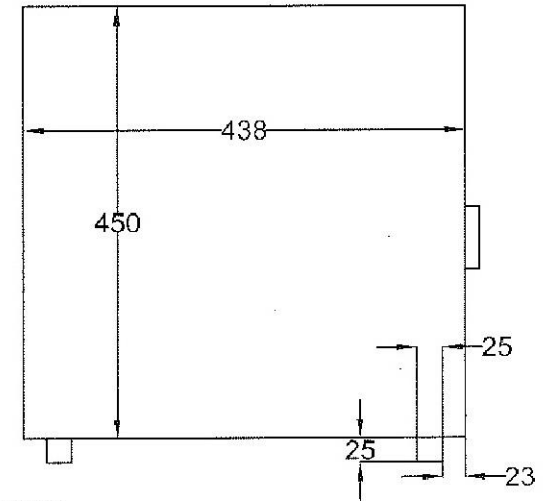

FRONT VIEW

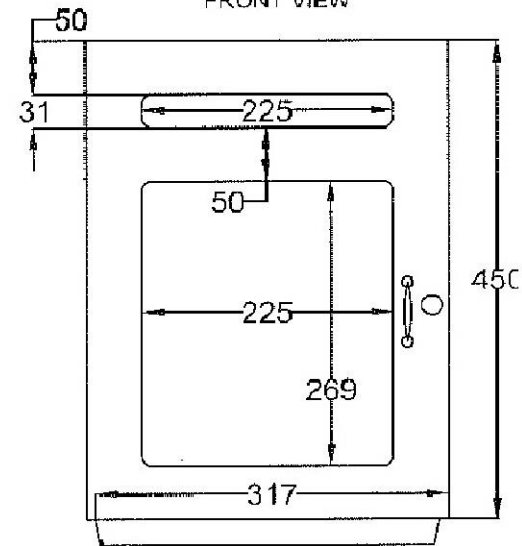

DESIGN & DRAWN BY:	
M.I.M. Abdul Hameed,	
Technical Officer/ Earth Science,	
Department of physical Sciences,	
Faculty of Applied Sciences,	
South Eastern University of Sri Lanka	
ALL DIMENSION ARE IN mm	
DATE 20.07.2016	NOT TO SCALE

FACULTY OF APPLIED SCIENCES  
 DEPARTMENT OF PHYSICAL SCIENCES/ EARTH SCIENCE UNIT  
 WOODEN MAP STORAGE CUPBOARD VIEW

(F7)

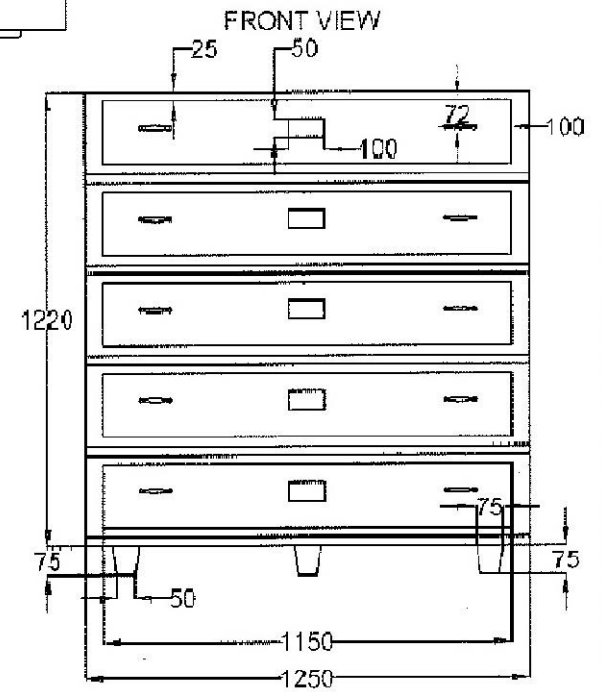
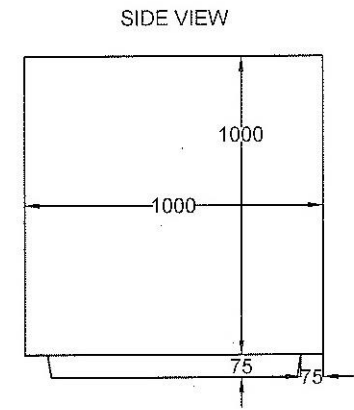
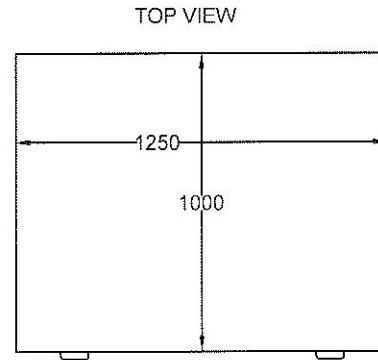
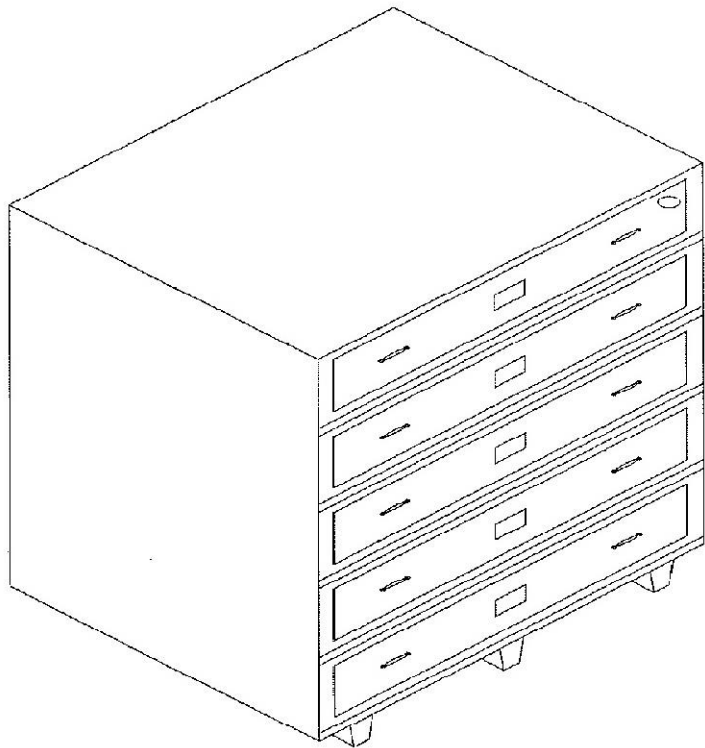

DESIGN & DRAWN BY:  
 M.I.M. Abdul Hameed,  
 Technical Officer/ Earth Science,  
 Department of physical Sciences,  
 Faculty of Applied Sciences,  
 South Eastern University of Sri Lanka

ALL DIMENSION ARE IN mm

DATE: 20.07.2016. NOT TO SCALE

FACULTY OF APPLIED SCIENCES  
 DEPARTMENT OF PHYSICAL SCIENCES/ EARTH SCIENCE UNIT  
 DEMONSTRATION TABLE VIEW

(F8)

TOP VIEW

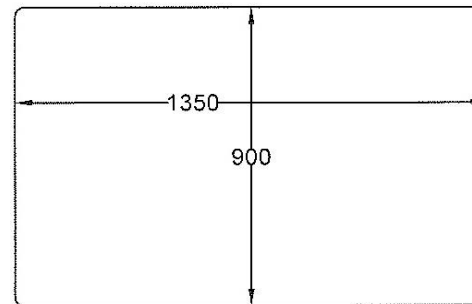

SIDE VIEW

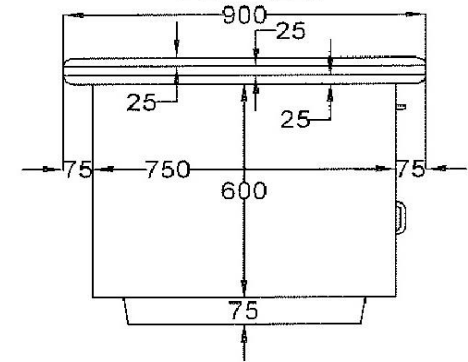

FRONT VIEW

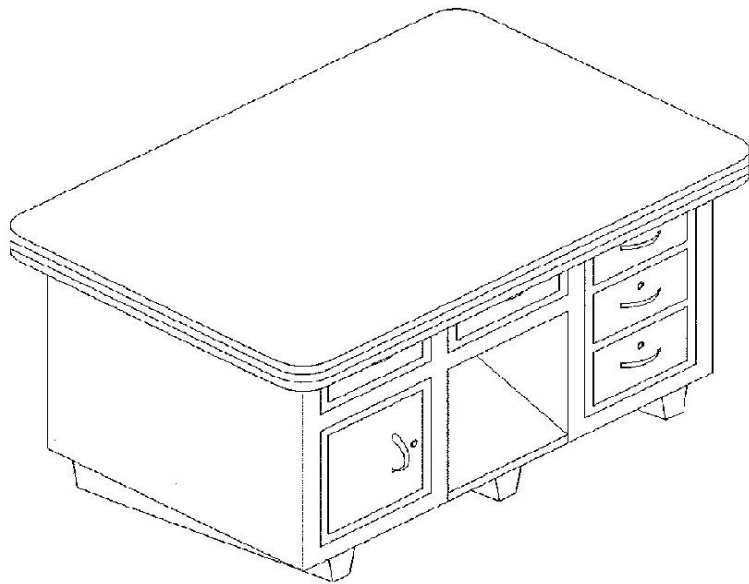
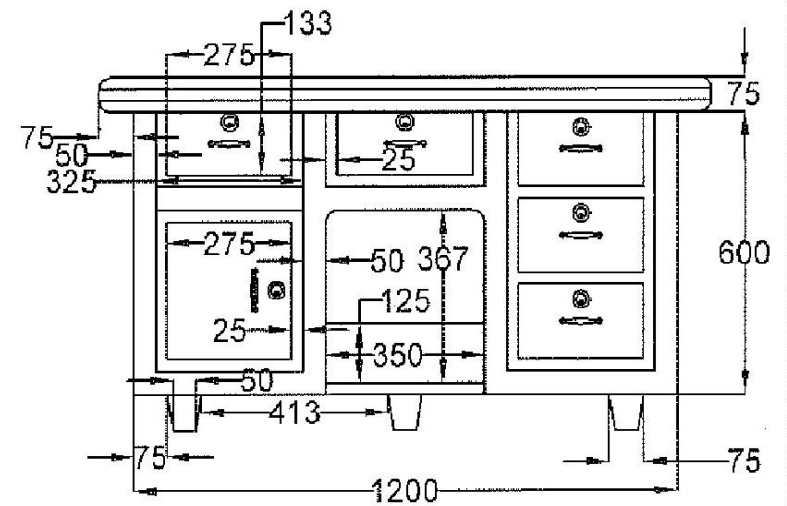

DESIGN & DRAWN BY:  
 M.I.M. Abdul Hamced.,  
 Technical Officer/ Earth Science,  
 Department of physical Sciences,  
 Faculty of Applied Sciences,  
 South Eastern University of Sri Lanka.

ALL DIMENSION ARE IN mm

DATE: 20.07.2016 NOT TO SCALE

**List of Goods and Delivery Schedule**

ANNEXURE - IV

Package No	Item No	Description of Goods	Qty	Final (Project Site) Destination as specified in BDS	Delivery Days	Bidders Response ( Delivery Days)
01	01	Laboratory Table with Accessories	12	Chemistry Laboratory, Department of Physical Science, at Faculty of applied Science at Sammanthurai, SEUSL.	90-120 days	
	02	Stool	150			
	03	Laboratory Head table with Accessories	05			
02	04	Laboratory Table with Accessories	64	Biology laboratory, Department of Biological Science, at Faculty of applied Science at Sammanthurai, SEUSL	90-120 days	
	05	Stool	130			
	06	Demonstration table with Accessories	01			
03	7	Laboratory Table with accessories	01	Earth Science Unit, Department of Biological Science, at Faculty of applied Science at Sammanthurai, SEUSL	90-120 days	
	8	Laboratory stool Type-I	30			
	9	Laboratory stool Type-II	20			
	10	Glassed Cupboard	08			
	11	Side Bench Solution Track	08			
	12	Record Book Box	03			
	13	Demonstration Table	05			

Authorized Officer's Signature:

Name of the company:

Date:

Company Seal

**SOUTH EASTERN UNIVERSITY OF SRI LANKA**

**SUPPLY, INSTALLATION AND COMMISSIONING OF LABORATORY  
FURNITURE**

**GENERAL TERMS AND CONDITIONS TO BE SIGNED AND SUBMITTED ALONG WITH  
OTHER DOCUMENTS BY THE BIDDER**

**INSTRUCTION TO BIDDERS**

**01. General Terms & Condition**

- V. Bid must be sent in the prescribed form annexed (Annexure I hereto). All the bidders should sign and send the documents attached to the Annexure II containing the general terms and conditions along with the documents listed in the clause 3-II hereto. The Cost of bidding documents are paid shall not be refunded.
- VI. Bids should be addressed only to the **Chairman, Procurement Committee, South Eastern University of Sri Lanka, Oluvil.**
- VII. Bids should be submitted in duplicate with all the blanks in the documents duly perfected signed and dated, as follows, in two separate sealed covers, distinctly marked on the top of left hand corner of the envelope.
- |                 |   |  |
|-----------------|---|--|
| c. Original bid | - | <b>Supply of Laboratory Furniture<br/>SEUSL/SS/FAS/NCB/G/2017/01</b> |
| d. Duplicate    | - | <b>Supply of Laboratory Furniture<br/>SEUSL/SS/FAS/NCB/G/2017/01</b> |
- VIII. Any alteration made in bids must bear the signature of the bidder and all bids containing alteration not so signed shall be treated as informal and rejected

**02. Closing & Opening of Bids**

Both sealed envelopes should be enclosed in one securely sealed cover and should be forwarded by Registered Post or deposited in the Official Tender Box kept at the Vice Chancellor's Office of the South Eastern University of Sri Lanka addressed only to the **Chairman, Procurement Committee, South Eastern University of Sri Lanka on or before 22<sup>nd</sup> March 2017 at 2 .30 pm.**

**Bid closing date & Time: 22<sup>nd</sup> March 2017 at 2 .30 pm**

.....  
Seal & Signature of the Bidder



If either the original or the duplicate document thereof is not received by the date and time specified the bid shall not be accepted on any account. Bids will be opened at 3.00 pm on **22<sup>nd</sup> March 2017** at the Board Room - 2, Ground Floor, Administrative Building, South Eastern University of Sri Lanka, University Park, Oluvil # 32360.

The Bidder or one of his authorized representatives is permitted to be present at the opening of the bids.

### **03. Payment of Non-Refundable Fee**

- IV. Non-refundable fee of Rs. 5,000/= should be paid either to the Shroff, South Eastern University of Sri Lanka or **Bank Draft drawn** in favor of the “**Bursar, South Eastern University of Sri Lanka, University Park, Oluvil # 32360** and the photo copy of the receipt/bank draft should be attached to the bidding documents. Those who are obtaining the bidding documents from the University website could also pay the non-refundable fee of Rs. 5,000/= to the above said Bank Account or by obtaining a Bank Draft in favour of the Bursar, South Eastern University, Sri Lanka.
- V. The bid should be made in accordance with the bidding documents consisting of the following documents
  - a. General Condition
  - b. Bid Submission Form (Annexure I)
  - c. Price Schedule (Annexure II)
  - d. Bid Security (Annexure III)
  - e. Performance Security ( Annexure IV)
  - f. Technical Specification ( Annexure V)
  - g. Copy of the Business Registration Certificate / Certificate of Incorporation / and Trading License from the local authority.
  - h. Document to support past Performance.
  - i. Any other document.
- VI. Conformity with conditions and specifications all the items offered must be strictly conformed to the specifications of the Laboratory equipments and to the contents of this document. The offer must address itself specifically to the individual specifications and state whether the items offered conform or do not conform therewith. The bidder shall submit the bid in the format given at the relevant annexure, failure to do so, it will lead to rejection.

### **04. Qualification of the Bidder**

- a. All bidders shall possess legal right to supply of goods under this procurement.
- b. All bidders shall produce a copy of the Business Registration Certificate/ Certificate of Incorporation (if the bidder is a Company) registered under the Companies Act.

.....  
Seal & Signature of the Bidder

- c. Only the bidders who are engaged in the production / business of Laboratory equipments at least for the last three years shall only be qualified to submit the bid. During that period the bidder should have similar type of supplies, completed which contract value should be exceed **Rs.3 Million**. To prove these copies of agreement or order and completion certificates should be attached with the bidding documents.
- d. No bidder whose name is black listed by the Treasury shall be qualified to submit bid.
- e. A bidder shall not have a conflict of interest. All bidders found to have conflict of interest shall be disqualified.
- f. Any attempt on the part of the bidder or their agents to influence to the Officials of the University in their favour by personal canvassing with the Officers concerned or any other party shall disqualify the bidders.
- g. Having a service center in nearby area will be considered as an added qualification.

#### **05. Prices & Currencies**

The bidders shall quote the price in Sri Lankan rupees only.

#### **06. The validity of Bid**

Bid shall be valid for 90 days from the date of the closing of the bids. Bid shall not be withdrawn during the period of validity of the bids.

Bid should be firm subject to no variations for fluctuations of prices.

#### **07. The Value Added Tax (VAT)**

The bidder shall indicate the amount of VAT, separately in the bidding documents, in addition to the net value of the bid, along with the VAT Registration number

If the bidder not registered for VAT, the net value of the bid should be indicated in the bidding documents and a letter obtained from the Commissioner of Inland Revenue Department certifying that the bidder had not registered for VAT, should be attached with the bid documents.

If the bidder has not indicated the VAT registration number or failed to submit the letter obtained from the Department of Inland Revenue, bids shall not be considered for evaluation and shall be rejected.

.....  
Seal & Signature of the Bidder

## **08. Liquidated Damages**

The successful bidder shall supply, install and commission the item for which he has been issued with the order within 60 days time, from the date of the acceptance of order. In case of delayed supplies, installation and commissioning liquidated damage at the rate of Rs.5,000/- per day will be levied for maximum 04 weeks.

Bidders should be prepared to accept orders subject to the penalty clause forfeiture of performance security in the event of default in supplies or failure to supply within the stipulated period.

## **09. Bid Security**

The Bid Security furnished should be equivalent to the amount shown in the Schedule I, for each category of items. The Security should be given from a recognized Bank operates in Sri Lanka valid for **120 days from Bid opening date** in favour of the Vice-Chancellor, South Eastern University of Sri Lanka (Insurance Bond will not be accepted). Bids Submitted without the bid security shall be treated as informal and be rejected.

If the Bidder wishes to submit his bid for a part of this procurement will be accepted and should submit the Bid Security only for the bidding package.

## **10. Performance Security**

Before a formal Agreement is signed, the successful bidder shall be required to furnish a Performance Security for 10% of the contract sum from an approved Bank in the prescribed form as per Annexure, in the name of the Vice-Chancellor, South Eastern University of Sri Lanka, University Park, Oluvil #32360 for the validity period of 120 days (Contract period 90 days + additional 30 days)

## **11. Forfeiture of Performance Security**

- (a) The goods that will be supplied should be strictly be conformed to the quality and the specification as per the order given. If they are found not in par with the order shall be rejected and the Performance Security shall be forfeited to the University. The University shall not be responsible for paying any expenses or losses that may occur to the supplier in supplying the goods, non conformity with the order.
- (b) In case where a successful bidder, after having made partial supply fails to fulfill the contracts in full, all or any of the items not supplied may of the discretions of the University be purchased by means of another procurement or by negotiation or from the next higher bidder who had offered to supply already and the loss, if any caused to the University shall thereby together with the sum as may be fixed by the University towards the damages, be recovered from the defaulting bidder by forfeiting the performance security.

.....  
Seal & Signature of the Bidder

## 12. Evaluation of Bid

- a) The Bids will be evaluated package basis.
- b) Only substantial responsive bids will be referred to the Technical Evaluation Committee for further evaluation and recommendation and subsequently to the Procurement Committee for a decision.
- c) The final acceptance of the procurement rests entirely to the University. The University shall not bind itself to accept the lowest or any bid. It reserves the right of accepting or rejecting any of the bids. The bidders of their part should be prepared to supply the items ordered from them what they have quoted in the bidding documents.
- d) The TEC may request samples in order to assist the selection process and check the stated quality

### e) Notification of Acceptance

The successful bidder will be notified by registered post, the acceptance of bid by the University. The successful bidder shall also execute an agreement, for the due fulfillment of the contract within the period to be specified in the letter of acceptance. If the bidder within ten days of being noticed declines or fails to enter into an agreement on the basis of the procurement and/or fails to submit the Performance Security referred to in paragraph 11 of these conditions, his bid shall be rejected.

The official intends will be placed with the successful bidder after the submission of Performance Security referred to in paragraph 11 of the conditions.

### f) Delivering, Installation and Commissioning,

- c) The bidder will be responsible for proper packing, transport and deliver the furniture to the South Eastern University of Sri Lanka.
- d) The furniture should be assembled, installed as directed by the University and commissioned soon after the items are delivered.

### g) Payment Terms

- c) Payment will be made by cheque drawn in favour of the **Business name of the bidder with "Account Payee only" crossing.**
- d) The payment will be made as follows,

III.	Delivery and installation of Goods	-	80% of the value
IV.	Commissioning of Goods	-	20% of the value

.....  
Seal & Signature of the Bidder

**h) Assigning & Subletting of Contract.**

The selected bidder shall not assign or sublet the supply or any part of thereof.

**i) Termination of Contract.**

The Chairman University Procurement Committee of the South Eastern University of Sri Lanka may without prejudice to any other remedy for breach of contract written notice of default send to the supplier terminate the contract in whole or part thereof.

Or

If the Contractor fails to perform any other obligation under the contract and if the Contractor, in either of the above circumstances does not response within a period of 10 days after receipt of the notice of default from the Chairman specifying the nature of the defaulters.

If any further information is needed, that could be obtained from the Assistant Bursar/Stores and Supplies SEUSL on any working day between 9.00 a.m and 3.00 p.m on Telephone Numbers: 067 2255178

**j) Clarification of Bidding Documents**

a). A prospective Bidder requiring any clarification of the Bidding Documents including the restrictiveness of specifications shall contact the Purchaser in writing at the **Senior Assistant Bursar, South Eastern University of Sri Lanka, University Park, Oluvil # 32360** marked as **“Supply, Installation & Commissioning of Laboratory Furniture- SEU/SS/FAS/NCB/2017/01”**. The letter should reach no later than ten (10) days prior to the deadline for submission of bids.

b). Pre-Bid meeting is scheduled to be held at 02.30 pm on **10<sup>th</sup> March 2017** at The Board Room - 2, Ground Floor, Administrative Building, South Eastern University of Sri Lanka, University Park, Oluvil # 32360.

.....  
Seal & Signature of the Bidder

**ANNEXURE V**

**PROCUREMENT OF SUPPLY, INSTALLATION AND COMMISSIONING OF  
LABORATORY FURNITURE FOR SOUTH EASTERN UNIVERSITY, SRI LANKA**  
**SEUSL/SS/FAS/NCB/G/2017/01**

**SPECIMEN FORM OF BID SECURITY**

By this Security we.....  
( Here in after called “the Bidder”) and we (Name of Bank) whose registered office is at  
.....(Here in after called “the  
Security”) are held and firmly bound unto .....  
(Hereinafter called “the Authority”) in the sum of .....  
..... for the payment of which sum the Tendered and the  
Surety bind themselves their successors and assigns jointly and severally these presents.

Whereas the Authority has invited the Bidder and other persons to complete Bids in similar terms for the supply and delivery of Laboratory Equipments herewith (hereinafter called “the Laboratory Equipments”) and to submit the same for the consideration of the Authority, and the Bid proposes to submit to the authority a Bid (hereinafter called “the Bid”) . In accordance with such invitation, the Security shall provide Security to the Authority that the Bidder will honour certain obligations to be undertaken by him in the Bids in accordance with the following conditions.

**Now the Conditions of this Security are:**

- a) That it shall remain in full force and effect until the earliest of
  - (i) (date) , being ( ) days from (submission date), the date stipulated by the Authority for the submission of Bids, or any prolongation of such date above notified to the Authority by the Bidder and the Surety in writing.
  - (ii) in the event of acceptance of the Bids by the Authority, the date upon which the Bidder provides a performance security to the Authority in accordance with the terms of the contract thereby made between them, or
  - (iii) In the event of acceptance by the Authority of a Bid for the Works from a third party, the date upon which such third party provides the relevant performances security.

- b) Subject to this Bond being in full force and effect, the Surety shall pay the full amount specified in this security upon receipt of first written demand from the Authority stating that
  - (i) The Bidder has withdrawn his Bid during the validity of this security, or
  - (ii) The Bidder has failed to provide a performance security to the Authority in accordance with the terms of the contract between them upon acceptance of the quotations.

No alteration in the terms of the Bids, nor any forbearance or forgiveness in or in respect of any matter or thing concerning the Bid on the part of the Authority, nor any objection from the bidder shall in any way release the Surety from any liability under this security. The benefit of this security shall not be assignable by the Authority and upon its ceasing to be in full force and effect the Authority shall return the same to the Bid.

The Security shall be governed by the Laws of ( )

I executed as a Deed this ( ) day of ( ) 20 ( )

For and on behalf of the Bidder.....

For and behalf of the Surety.....

.....

.....

Signed by .....

Signed by:.....

In the capacity of .....

In the capacity of.....

And by .....

And by .....

In the capacity of.....

In the capacity of.....

Seal (where applicable)

Seal (where applicable)

ANNEXURE VI

**SPECIMEN FORM FOR PERFORMANCE SECURITY**

.....(Issuing Agency’s Name , and Address of Issuing Branch or Office) .....

Beneficiary:.....(Name and Address of Employer).....

.....

Date:.....

**PERFORMANCE SECURITY NO:** .....

We have been informed that ..... [Name of Contractor/Supplier (Hereinafter called “the Contractor”)]has entered into Contract No.....(reference number of the contract) dated.....with you , for the .....(insert “Construction”/ “Supply”) of .....(name of contract and brief description of works) (hereinafter called “the Contract”)

Furthermore, we understand that, according to the conditions of the Contract, a Performance Security is required.

At the request of the Contractor, we.....( name of Agency) hereby irrevocably undertake to pay you any sum or sums not exceed ing in total an amount of .....[amount in figure] .....(amount in words), such sum being payable in the types and proportions of currencies in which the Contract Price is payable, upon receipt by us of your first demand in writing accompanied by a written statement stating that the Contractor is in breach of its obligations(s) under the Contract, without your needing to prove or to show grounds for your demand or the sum specified herein.

This security shall expire, no later than the .....day of .....20.....(insert date, 120 days beyond the scheduled contract completion date) and any demand for payment under it must be received by us at this office on or before that date.

.....

**Signature(s)**



**Specimen Manufacturer's Authorization**

Date: *[insert date (as day, month and year) of Bid Submission]*

No.: SEUSL/SS/FAS/NCB/G/2017/01

To: Vice Chancellor  
South Eastern University of Sri Lanka  
University Park  
Olivil # 32360

WHEREAS

We *[insert complete name of Manufacturer]*, who are official manufacturers of *[insert type of goods manufactured]*, having factories at *[insert full address of Manufacturer's factories]*, do hereby authorize *[insert complete name of Bidder]* to submit a bid the purpose of which is to provide the following Goods, manufactured by us *[insert name and or brief description of the Goods]*, and to subsequently negotiate and sign the Contract.

We hereby extend our full guarantee and warranty in accordance with Clause 27 of the Conditions of Contract, with respect to the Goods offered by the above firm.

Signed: *[insert signature(s) of authorized representative(s) of the Manufacturer]*

Name: *[insert complete name(s) of authorized representative(s) of the Manufacturer]*

Title: *[insert title]*

Duly authorized to sign this Authorization on behalf of: *[insert complete name of Bidder]*

Dated on \_\_\_\_\_ day of \_\_\_\_\_, \_\_\_\_\_ *[insert date of signing]*